

# INSTRUCTION BOOK

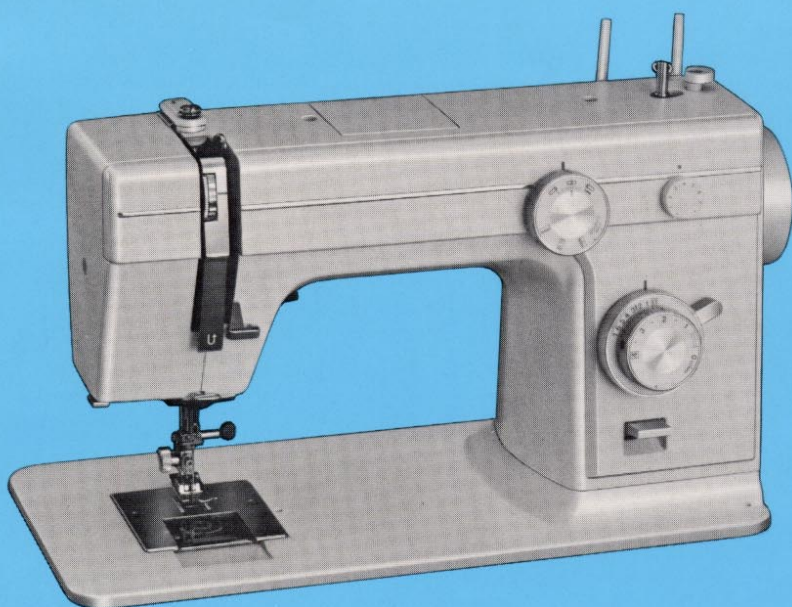

**Model 808**

[www.promelectroavtomat.ru](http://www.promelectroavtomat.ru)

# TABLE OF CONTENTS

## SECTION I ESSENTIAL PARTS

Names of Parts . . . . .	2
--------------------------	---

## SECTION II GETTING READY TO SEW

Connecting the Machine to the Power Supply . . . . .	3
Foot Control . . . . .	3
Raising or Lowering the Needle . . . . .	4
Raising or Lowering the Presser Foot . . . . .	4
To Drop the Feed Dog . . . . .	4
To Snap On and Snap Off the Presser Foot . . . . .	5
To Remove and Attach the Foot Holder . . . . .	5
Removing the Bobbin . . . . .	6
Sewing Light . . . . .	6
Winding the Bobbin . . . . .	7
Inserting the Bobbin . . . . .	8
Threading the Machine . . . . .	9
Drawing up Bobbin Thread . . . . .	10
Thread and Needle Chart . . . . .	11
Changing Needles . . . . .	11
Balancing Needle Thread Tension . . . . .	12
Thread Tension for Zigzag Sewing . . . . .	12
Stitch Selector Dial . . . . .	13
Stitch Length Dial . . . . .	14
Stitch Width Dial . . . . .	14
Reverse Stitch Lever . . . . .	15
Seam Guide Line . . . . .	15

## SECTION III BASIC SEWING

Straight Stitch Sewing . . . . .	16~17
Zigzag Stitching . . . . .	18~19
● Changing Cams . . . . .	18
Automatic Pattern Sewing . . . . .	20
● How to Keep the Seam Straight . . . . .	21
Overcasting . . . . .	22

Overedge Stitch . . . . .	22
Tricot Stitch . . . . .	23
Outline Stretch Stitch . . . . .	23
Triple Strength Stitch . . . . .	24
Buttonholes . . . . .	25~26
Corded Buttonhole . . . . .	27
Zipper Application . . . . .	28~29
Blind Stitch Hemming . . . . .	30
Rolled Hem . . . . .	31~32

## SECTION IV PERSONAL TOUCH OR DECORATIVE SEWING

Twin Needle Stitching . . . . .	33~34
Pintucking . . . . .	34
Cording . . . . .	35
Quilting . . . . .	36
Smocking . . . . .	37
Shell Tuck . . . . .	38
Scallop Hems . . . . .	39
Decorative Scallop . . . . .	40
Lace Work . . . . .	41
Patch Work . . . . .	42
Fagoting . . . . .	42
Applique . . . . .	43
Drawn Work and Fringing . . . . .	44
Free Hand Machine Embroidery . . . . .	45

## SECTION V CARING FOR YOUR MACHINE

Oiling the Machine . . . . .	46
Cleaning the Bobbin Holder . . . . .	47
Cleaning the Hook Race and Feed Dog . . . . .	48~49
Resetting the Bobbin Holder and Needle Plate . . . . .	50
Trouble Shooting . . . . .	51~52

## SECTION I ESSENTIAL PARTS

### Names of Parts

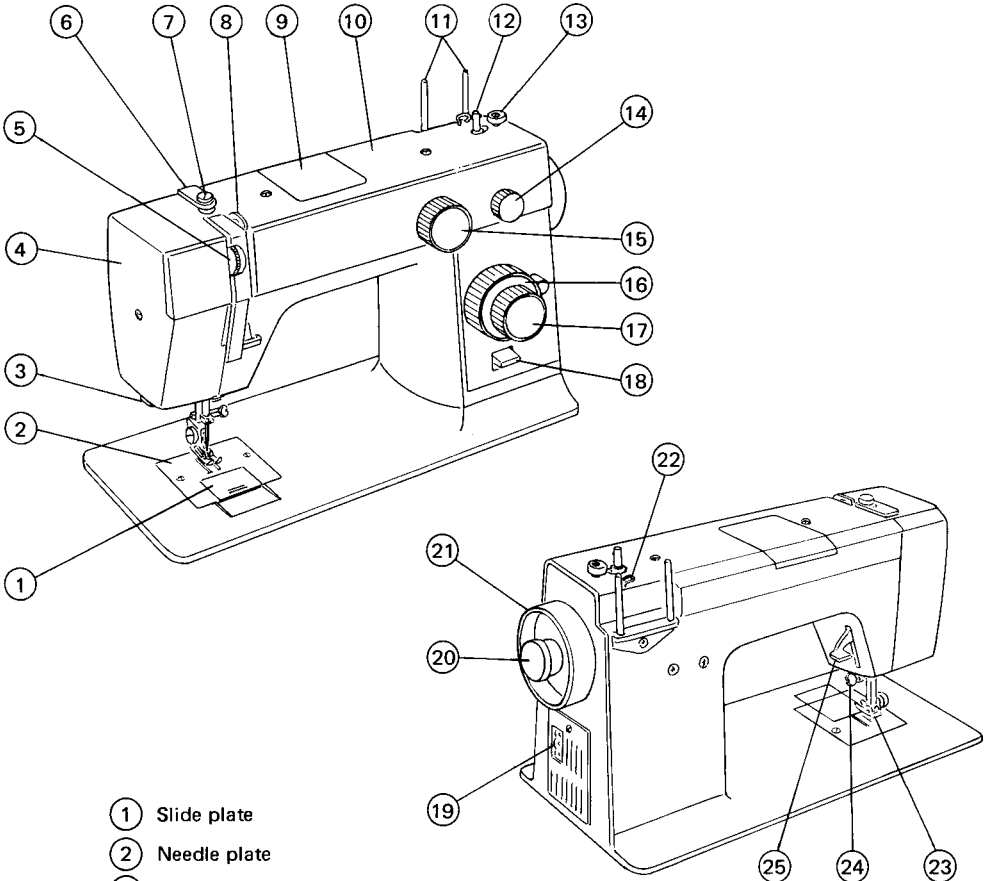

- ① Slide plate
- ② Needle plate
- ③ Thread cutter
- ④ Face plate
- ⑤ Thread tension dial
- ⑥ Upper thread guide
- ⑦ Bobbin winder thread guide
- ⑧ Thread take-up lever
- ⑨ Cam compartment lid
- ⑩ Top cover
- ⑪ Spool pins
- ⑫ Bobbin winder spindle
- ⑬ Bobbin winder stopper
- ⑭ Super pattern elongator

- ⑮ Stitch selector dial
- ⑯ Stitch width dial
- ⑰ Stitch length dial
- ⑱ Reverse stitch lever
- ⑲ Machine socket
- ⑳ Bobbin winder clutch knob
- ㉑ Balance wheel
- ㉒ Top cover thread guide
- ㉓ Presser foot
- ㉔ Needle clamp screw
- ㉕ Presser foot lifter

## SECTION II GETTING READY TO SEW

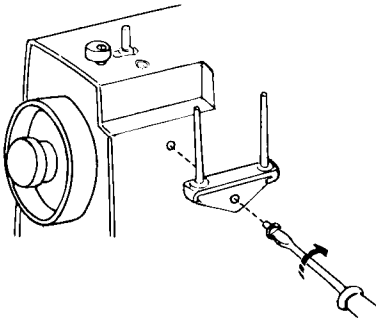

### How to set the spool pins

Spool pins are separately packed to prevent any damage in transit.

Therefore, fix the holder of spool pins in place with a screw driver, as shown in the figure.

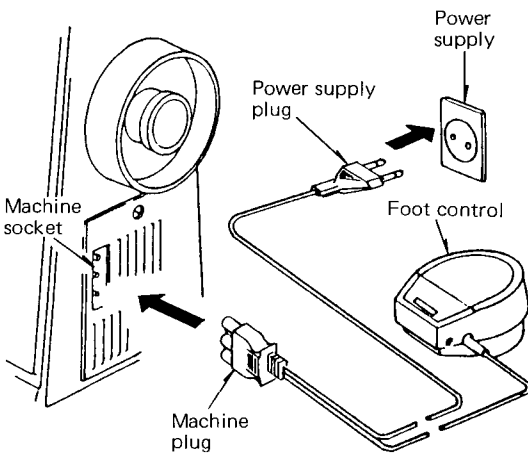

### Connecting the Machine to the Power Supply

Before connecting the power, make sure the voltage and number of cycles of the machine conform to your electrical power.

Fit the nonreversible plug into the machine socket and plug the machine into the power supply.

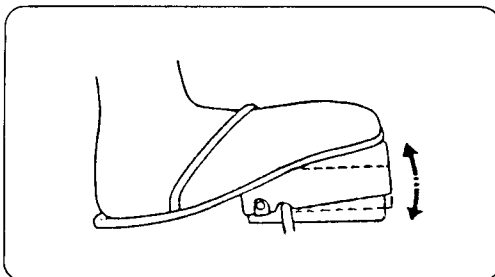

### Foot Control

Sewing speed can be varied by the foot control.

The harder you press on the control, the faster the machine runs.

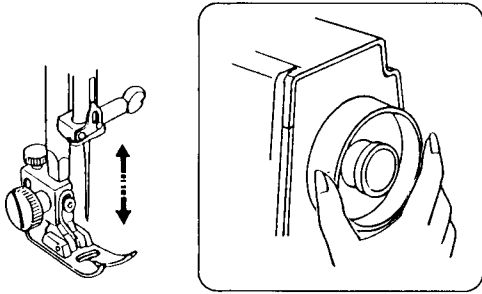

### Raising or Lowering the Needle

Turn the balance wheel toward you to raise or to lower the needle to the desired position.

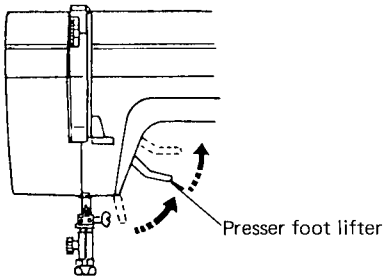

### Raising or Lowering the Presser Foot

The presser foot lifter raises or lowers the presser foot.

When the presser foot lifter is in the up position, an extra push upwards provides you with an extra high lift allowing you to slide in bulky fabrics with ease.

### To Drop the Feed Dog

When sewing free hand embroidery, set the stitch length dial at "DOWN".

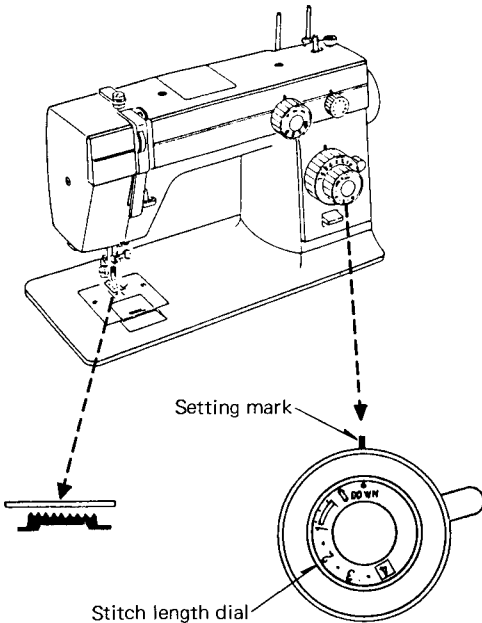

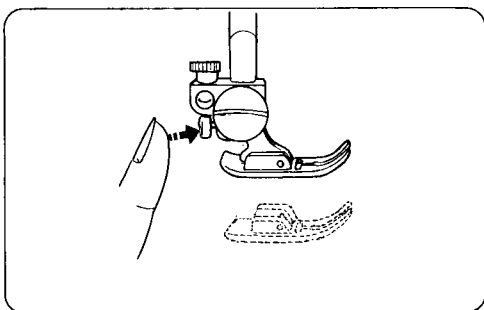

## To Snap On and Snap Off the Presser Foot

### « To Snap Off »

Raise the needle and the presser foot. Press the red button on the back of the foot holder. The presser foot will drop off.

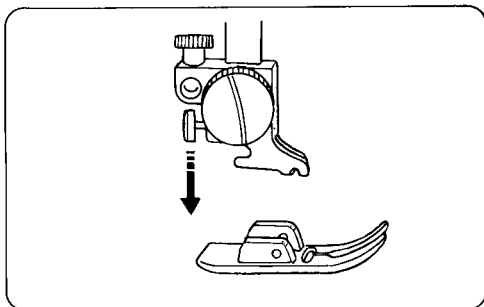

### « To Snap On »

Place the presser foot so the pin on the foot lies just under the groove of the foot holder. Lower the foot holder to lock the foot in place.

\* See page 28 for attaching zipper foot, and page 43 for applique foot.

## To Remove and Attach the Foot Holder

### « To Remove »

Remove the foot holder screw by turning the screw counter-clockwise with the large screwdriver.

### « To Attach »

Align the hole in the foot holder with the threaded hole in the presser bar and fit the foot holder screw into the hole. Tighten the screw by turning it clockwise.

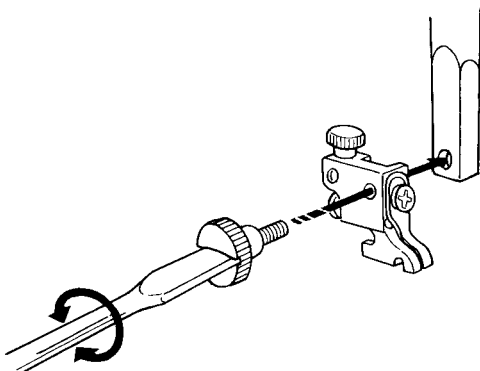

## Removing the Bobbin

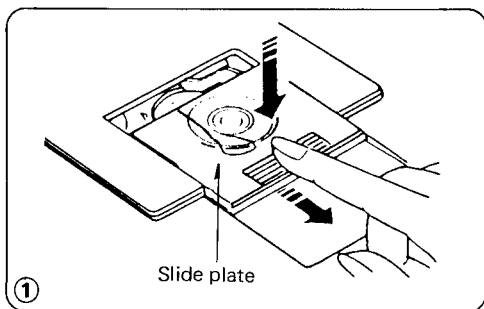

- ① Gently push slide plate down and slide it towards you.

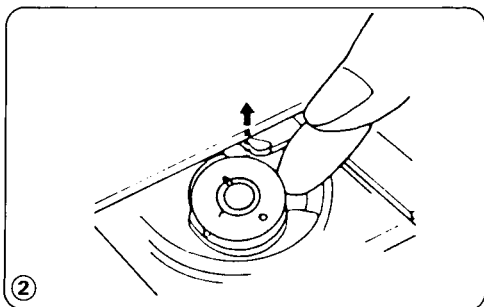

- ② Lift out the bobbin, as shown.

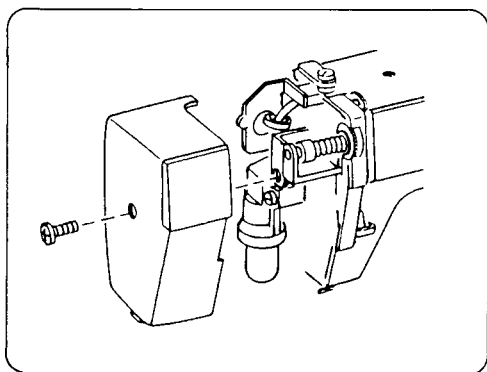

## Sewing Light

The sewing light is located behind the face plate.

Unscrew the set screw and remove the face plate.

- To remove . . . . Turn it counter-clockwise.
  - To replace . . . . Turn it clockwise.
- To remove . . . . Push and twist it counter-clockwise.
  - To replace . . . . Push and twist it clockwise.

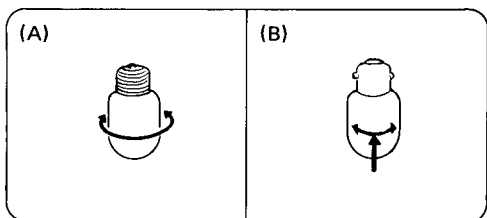

## CAUTION

- \* Before removing the face plate, unplug your machine.
- \* The sewing light may be HOT. Protect your fingers when you handle it.

## Winding the Bobbin

Put felt and spool of thread onto spool pin, with the thread winding in the direction as illustrated.

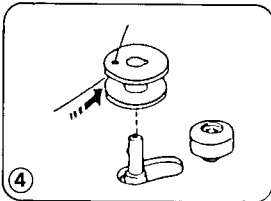
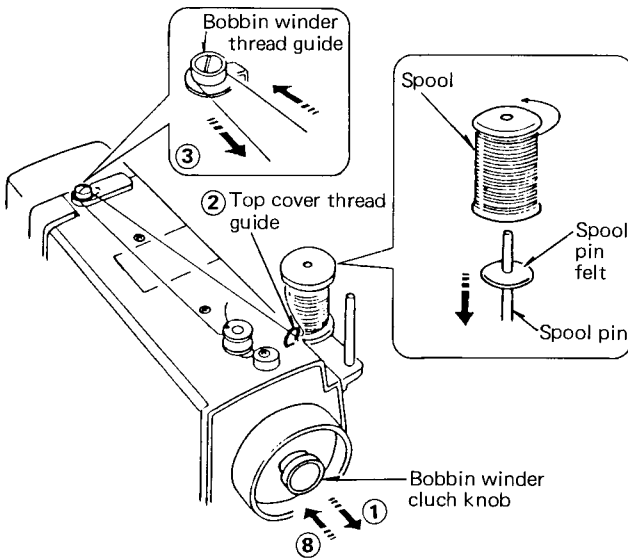

- 1 Pull the clutch knob away from the machine to disengage clutch.

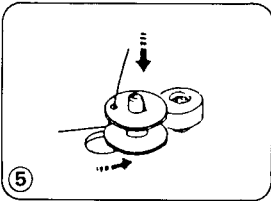

- 2 Draw the thread from the spool. Pass the thread through the top cover thread guide.
- 3 Guide the thread around the bobbin winder thread guide.

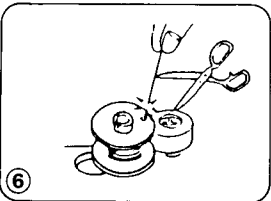

- 4 Insert the thread through the hole in the bobbin from inside to outside as shown.
- 5 Put the bobbin on the bobbin winder spindle, and push it to the right.

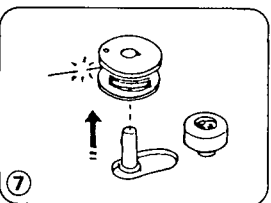

- 6 With the free end of the thread held in your hand, depress the foot control. Stop the machine when it has made a few turns, and cut the thread close to the hole in the bobbin.



- 7 Depress the foot control again and wind the thread until the bobbin stops. Move the bobbin winder spindle to its original position (left), and cut the thread.
- 8 Push in the clutch knob to engage clutch.

\* The machine will not sew until the clutch knob is pushed in.



## Inserting the Bobbin

- ① Place the bobbin in the bobbin holder with the thread running counter-clockwise.

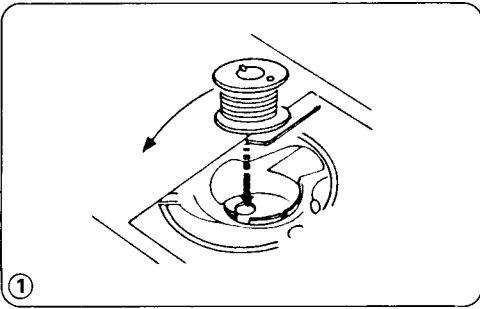

- ② Guide the thread into the notch A on the front side of the bobbin holder. Draw the thread to the left sliding it between the tension spring blades.

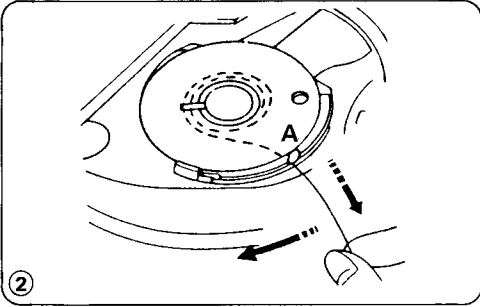

- ③ Continue to draw the thread lightly until the thread slips into notch B. Pull out about 15 cm (6'') of thread.

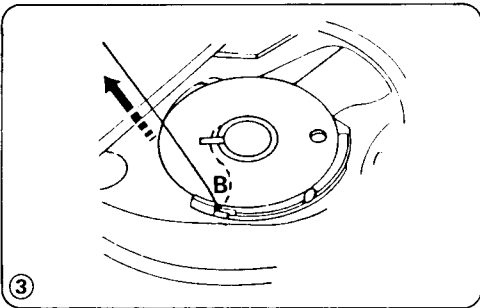

- ④ Close the slide plate. Check the threading by referring to the chart shown on the slide plate.

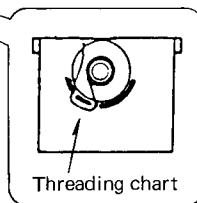
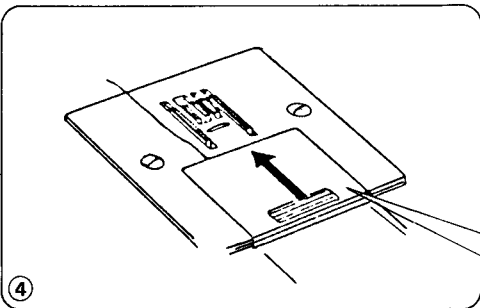

## Threading the Machine

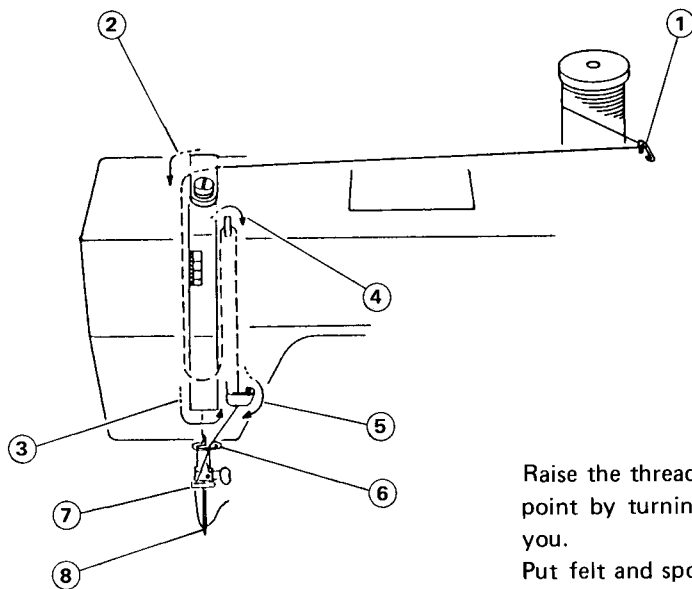

Raise the thread take-up lever to the highest point by turning the balance wheel toward you.

Put felt and spool on spool pin with thread coming from the left of the spool as shown.

Raise presser foot and pass the thread in the order from ① to ⑧.

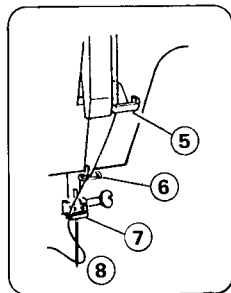
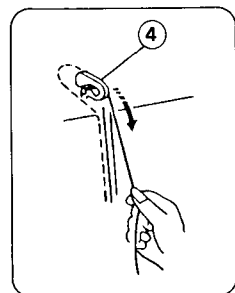
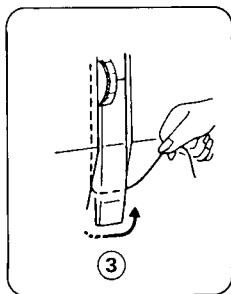
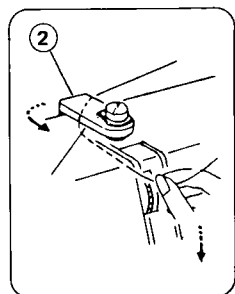

① Pass the thread through the top cover thread guide.

② Draw the thread through the upper cover thread guide.

③ While holding thread near spool, draw thread down into the tension area and then around the check spring holder.

④ Firmly draw the thread from left to right over the take-up lever and down into the take-up lever eye.

⑤⑥ Then pass through the lower thread guides.

⑦ Slide the thread behind the needle bar thread guide on the left.

⑧ Thread the needle from front to back.

## Drawing up Bobbin Thread

- ① Raise presser foot and hold the needle thread lightly with your left hand.

- ② Turn the balance wheel slowly toward you with your right hand until the needle goes down and continue turning balance wheel until the take-up lever is at its highest position.

- ③ Lightly draw up the needle thread forming a loop of the bobbin thread.

- ④ Draw 15 cm (6") of both threads to the back and under the presser foot.

# Thread and Needle Chart

	Fabrics	Threads	Needle Size
<b>Light weight</b>	Crepe de Chine, Voile	Fine Silk	9
	Lawn, Organdy, Georgette, Tricot	Fine Cotton Fine Synthetic Fine Cotton Covered Polyester	or 11
<b>Medium weight</b>	Linen, Cotton, Pique, Serge, Double Knits, Percale	50 silk	11
		50 to 80 Cotton	or
		50 to 60 Synthetic Cotton Covered Polyester	14
<b>Heavy weight</b>	Denim, Tweed, Gabardine, Coating, Drapery and Upholstery Fabric	50 silk	14
		40 to 50 Cotton	or
		40 to 50 Synthetic Cotton Covered Polyester	16

- In general, fine thread and needles are used for sewing thin fabrics, and thicker threads and needles are used for sewing heavy fabrics. Always test thread and needle size on a small piece of fabric which will be used for actual sewing.
- Use the same thread for needle and bobbin.
- When sewing stretch, very fine fabric or synthetics, use a **BLUE TIPPED** needle. The blue tipped needle effectively prevents skipped stitches.
- When sewing very fine fabrics, sew over a piece of paper to prevent yarn distortion.

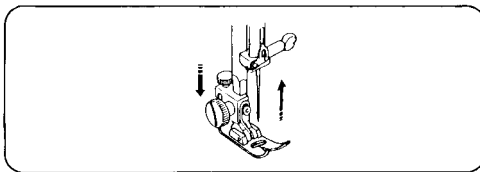

## Changing Needles

Raise the needle by turning the balance wheel toward you and lower the presser foot.

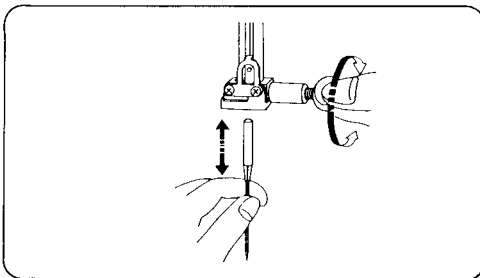

Loosen the needle clamp screw by turning it toward you.

Remove the needle from the clamp.

Insert the new needle into the needle clamp with the flat side away from you.

When inserting the needle into the clamp, push it up as far as it will go and tighten the clamp screw firmly with the screwdriver.

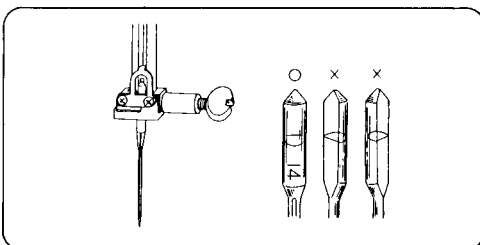

## Balancing Needle Thread Tension

The needle thread and the bobbin thread should interlock in the center of two layers of fabric in straight seams.

Set the desired number of the thread tension dial at setting mark.

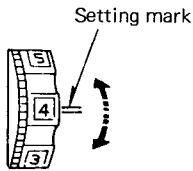

Loosen the needle thread tension by moving the dial to a lower number.

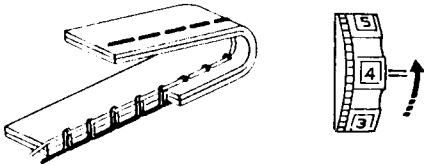

Tighten the needle thread tension by moving the dial to a higher number.

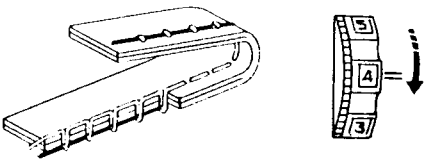

## Thread Tension for Zigzag Sewing

To obtain better zigzag stitches, the upper tension should be slightly weaker than that of straight sewing. The upper thread should appear slightly on the reverse side of the fabric.

## Stitch Selector Dial

Turn the dial and set at the setting mark when:

- \* Selecting the needle position.
- \* Sewing stitch pattern and buttonhole.
- \* Using twin needle.
- \* Opening cam compartment lid.

### ● Changing Needle Position





### ● Straight and Triple Strength Stitch

### ● Twin Needle Sewing

### ● Pattern Sewing:

Set the needle position at "  " when using the pattern cam nos. 9 to 24 and S-1 to S-16.

### ● Buttonholing:

Turn the dial in the order of "  →  →  →  "

### ● To Open the Cam Compartment Lid:

When the dial set at "  ", the cam compartment lid flips up for easy to change the drop-in pattern cam.

For closing, press down the lid.

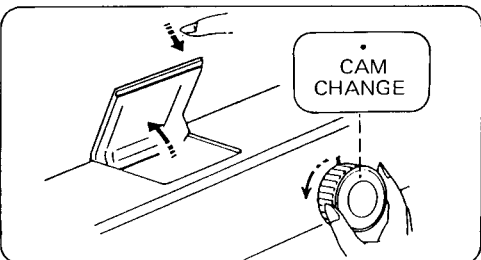
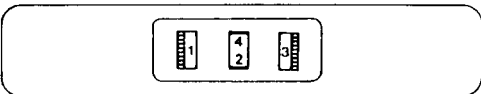
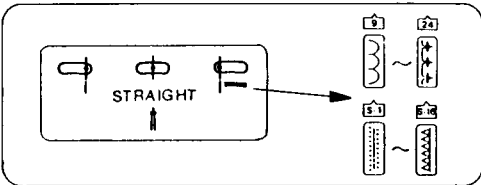
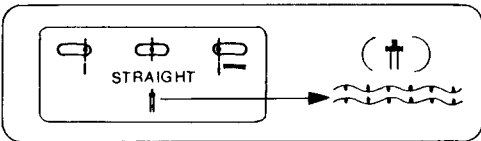
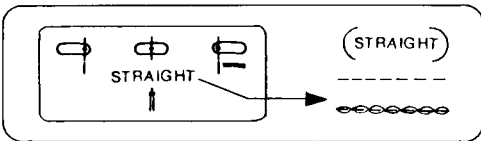
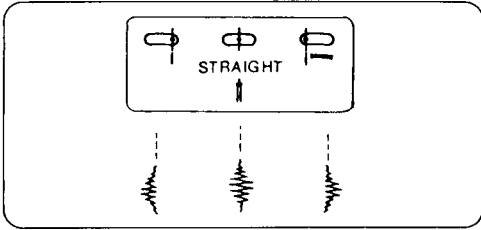
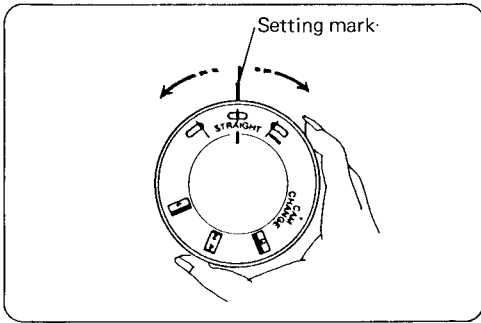

## Stitch Length Dial

You can select the suitable stitch length for fabrics that you plan to sew.

The higher the number, the longer the stitch length.

The symbol "  " indicates the range of stitch length adjustment for buttonhole.

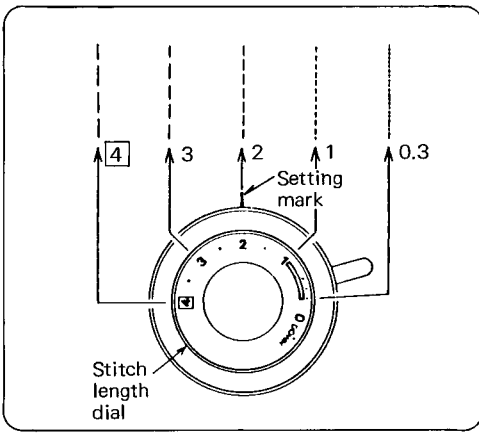

## Stitch Width Dial

\* The stitch width lever is provided to make the dial setting easier.

(To set stitch width)

Turn the stitch width dial to desired position and press it to stay.

(To release stitch width setting)

Turn the stitch width dial to " 0 " while pressing it.

\* Before turning the dial, make sure that the needle is out of the fabric.

The higher the number, wider the stitch width.

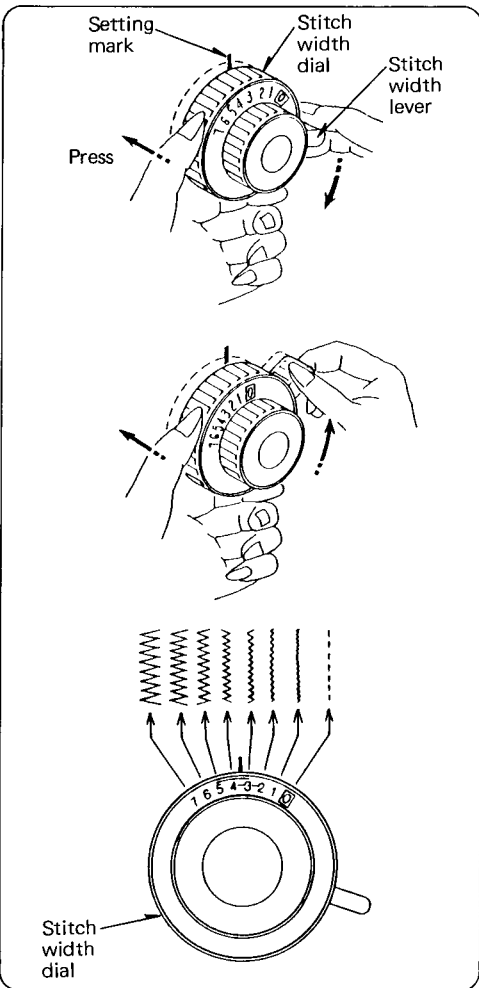

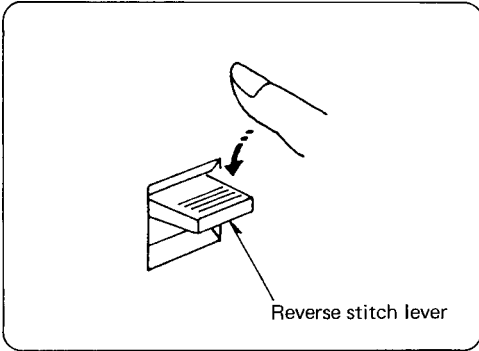

### Reverse Stitch Lever

Fabric is fed in reverse while the lever is pressed. When it is released, fabric is fed forward.

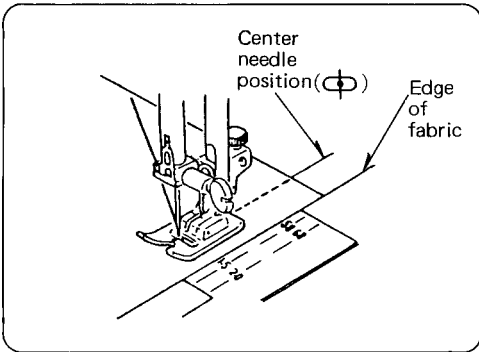

### Seam Guide Line

The numbers on the needle plate indicate the distance between the center needle position and the line.

The numbers in the front indicate in millimeter.

The numbers in the back indicate in inch.



## SECTION III BASIC SEWING

### Machine Setting

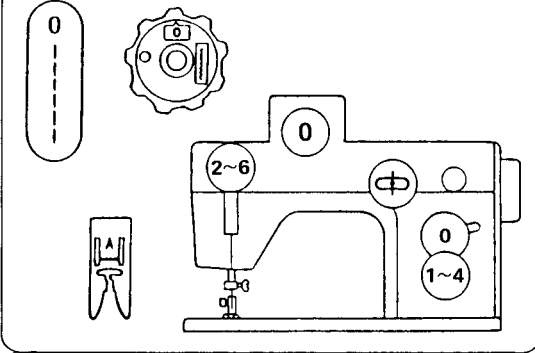

### Straight Stitch Sewing

The machine setting is always diagrammed in any article of sewing procedures.

The diagram corresponds with the machine as shown below.

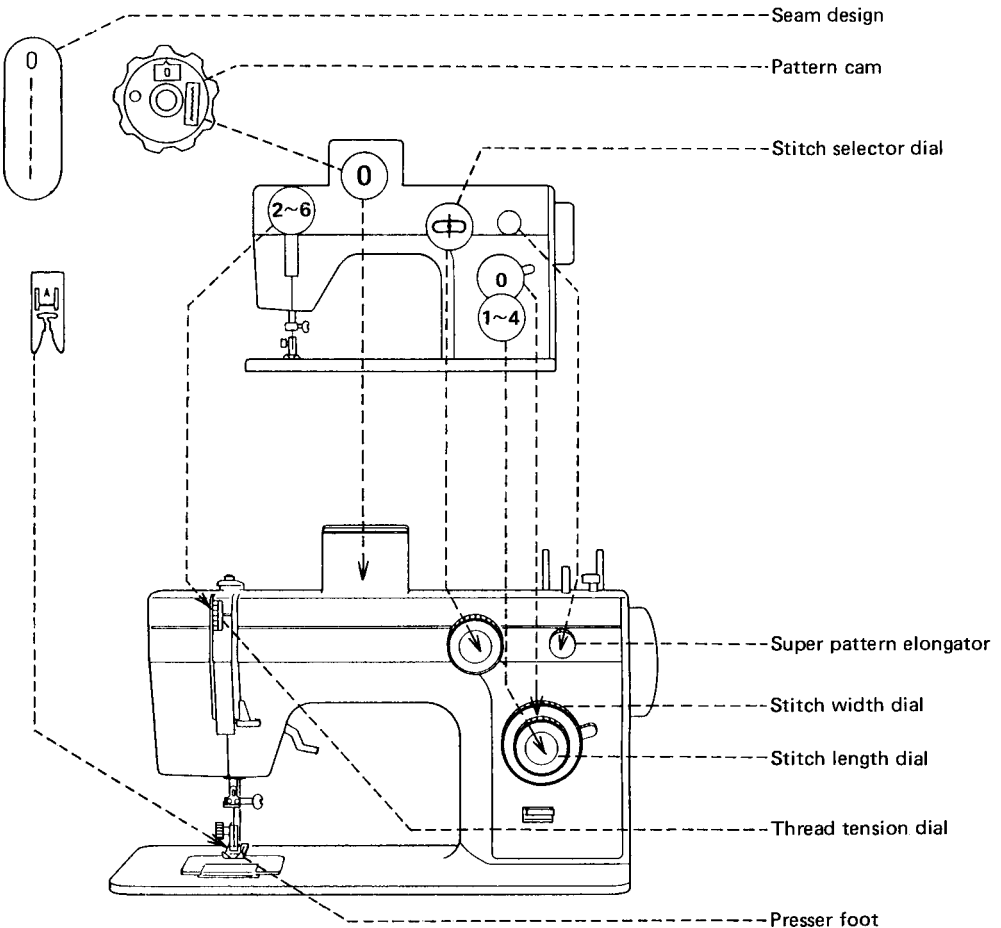

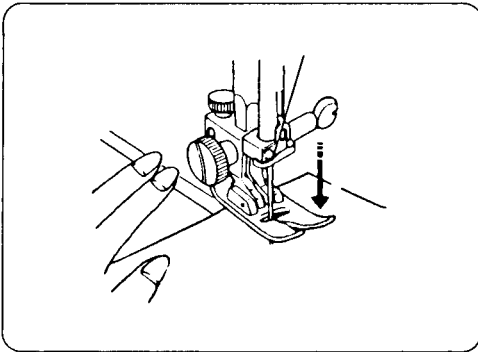

Raise the presser foot and lower the needle into the fabric at the start position.

Lower the presser foot and smooth the threads toward the back. Depress the foot control.

Gently guide the fabric along the guide line letting the fabric feed by itself.

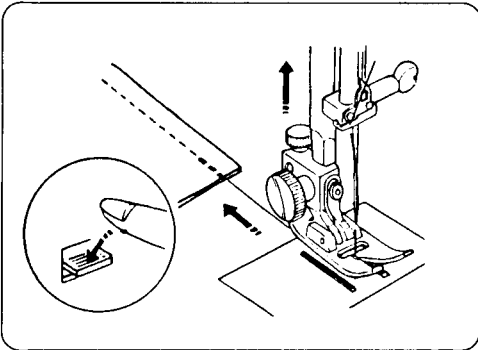

For fastening the ends of seams, press the reverse stitch lever and sew several reverse stitches.

Raise the presser foot and remove the fabric, drawing the threads to the back.

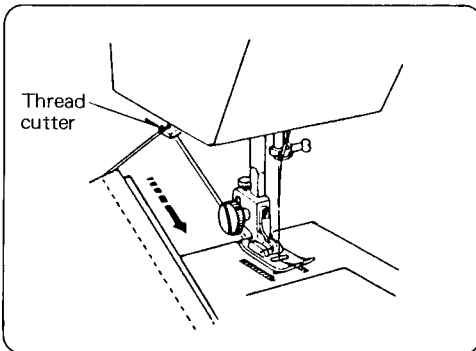

The threads are cut the proper length for starting the next seam.

Cut the threads with the thread cutter. By using the thread cutter, the proper length of threads remain to start next sewing.

## Machine Setting

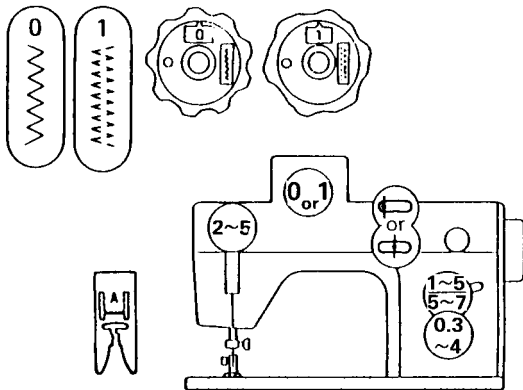

## Zigzag Stitching

Simple zigzag stitching is widely used for overcasting, appliqueing etc.

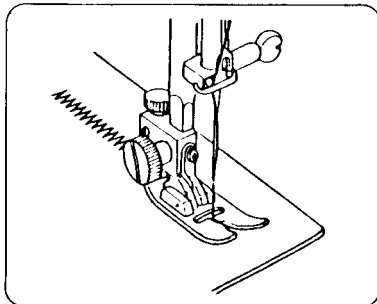

\* For pattern , stitch length should be set at 1 to 4 and stitch width at 1 to 5.

\* For pattern , stitch length should be set at 0.3 to 4 and stitch width at 5 to 7.

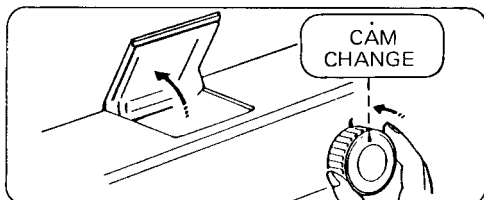

### « Changing Cams »

Set the stitch selector dial at " **CAM CHANGE** " to open the cam compartment lid.

Remove the cam from the holder shaft.

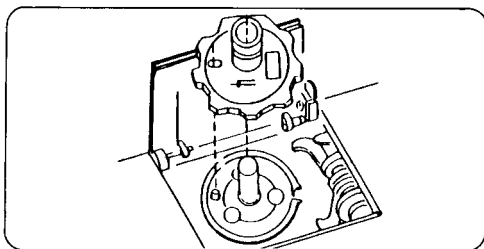

### « In Case of Cams Except Extra Cams E-1 through E-4 »

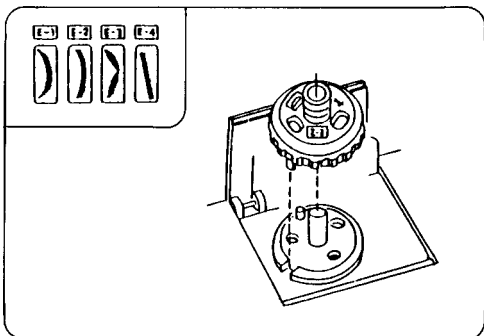

Place a new cam so that the large hole fits on the cam shaft and the small hole on the post. Press down the cam until it snaps in place.









### « In Case of Cams E-1 through E-4 »

Place a new cam in position so that its bottom lug fits into the notch of the cam shaft.

Press down the cam until it snaps in place.

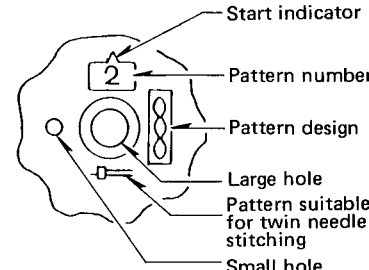
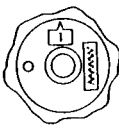
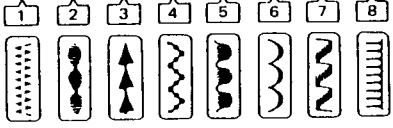
Align the start indicator  on the cam with the tip of the upper cam follower  by turning the balance wheel toward you, so that a complete stitch pattern can be sewn from its beginning.

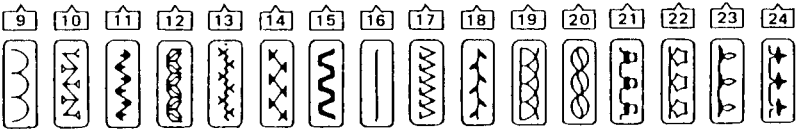
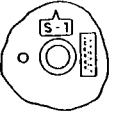
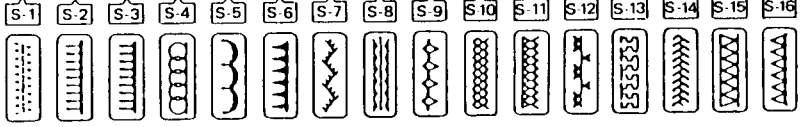
Just press the lid down to close.

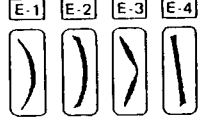

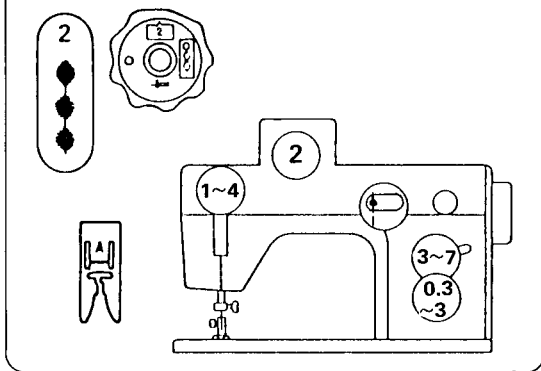

\* The start indicator on the pattern cams  through  is located at the edge of cams.

### Machine Setting (1)







### Automatic Pattern Sewing

All stitch patterns are produced by changing drop-in cams. The cam number and the pattern design are indicated on each cam.

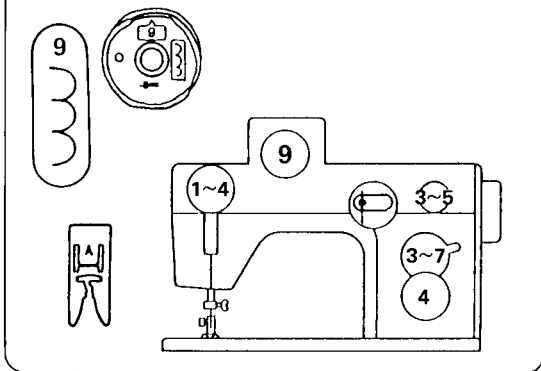
When you sew pattern numbers  through  ,  and  through  , set the machine as shown on the left.



### Machine Setting (2)

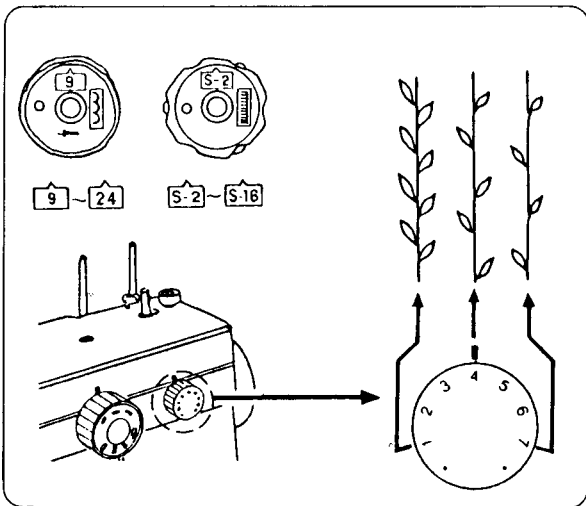

When you sew pattern numbers  through  and  through  , set the machine as shown on the left.

\* Stitch width should be between "1" and "5" for the pattern No. 15.



When you sew the patterns  through  and  , you can shorten or lengthen the pattern designs. The super pattern elongator should be set at the neutral position (4) for regular stitching.

To shorten the pattern, turn the dial toward large indicating numbers. Remember to return the dial to the neutral position (4) when the elongation work is completed.

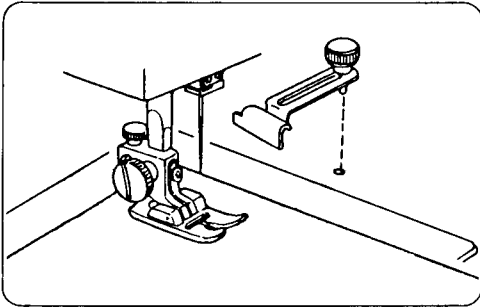

### « How to Keep the Seam Straight »

The cloth guide helps you to guide the stitches evenly.

To attach the cloth guide, place the screw in the hole to the right hand side of the needle plate.

Line up the straight edge of the guide with the needle plate for the desired seam width and tighten the screw.

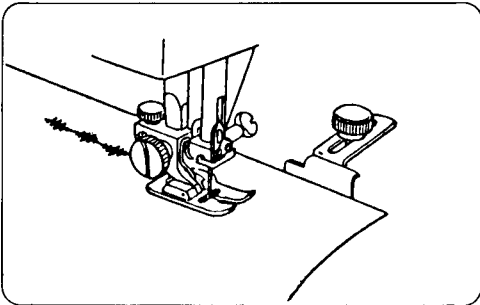

Keep the edge of the fabric touching against the cloth guide while sewing.

### Machine Setting

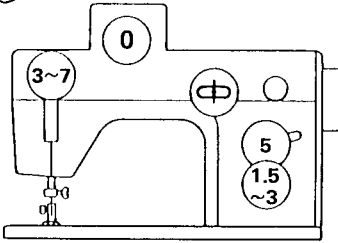

### Overcasting

This stitch can be used on most woven fabrics. It's the fastest way to finish and leaves you with a neat, flat edge.

Keep the edge of fabric touching against the black guide of the overedge foot while sewing.

This stitch is used on the seam allowance to prevent fabrics from fraying raw edges.

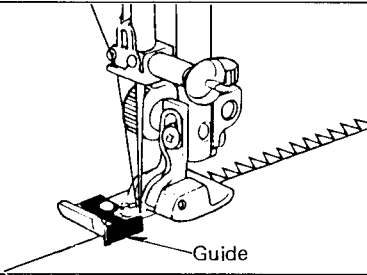

### Machine Setting

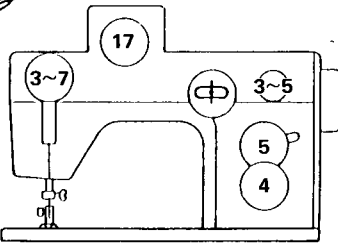

### Overedge Stitch

This type of stitch is suitable for over- edging and seaming on loosely woven fabrics and light weight stretch fabrics. Both overcasting and basic straight sewing are done simultaneously.

Keep the edge of the fabric touching against the black guide while stitching.

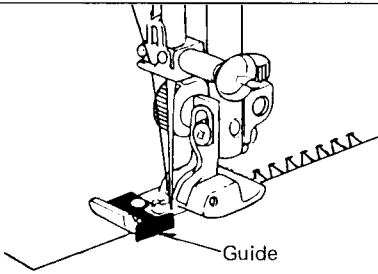

### Machine Setting

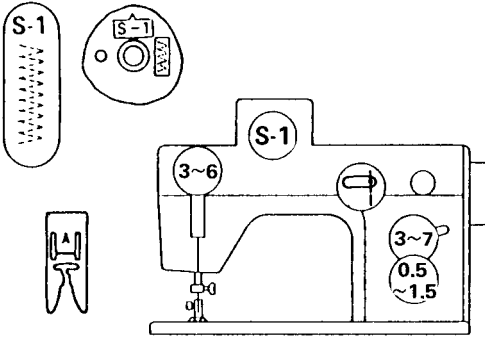

## Tricot Stitch

The tricot stitch is used to finish seam allowance on synthetics and other fabrics that tend to pucker.

The stitch is excellent for darning and mending tears in fabric.

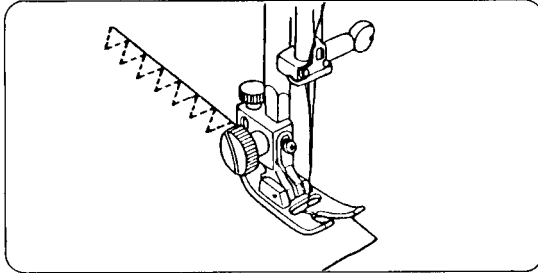

Place the fabric under the presser foot so that the edge will be slightly inside the right hand side of the presser foot. Guide the work so the right hand stitches fall at the edge of the fabric.

### Machine Setting

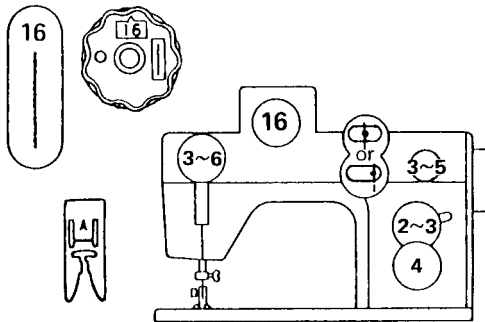

## Outline Stretch Stitch

This stitch is ideal for sewing jersey and other stretchy materials. Expanding and contracting with the material, its elasticity prevents breaking or fraying of thread.

\* The blue tipped needle is recommended to be used.

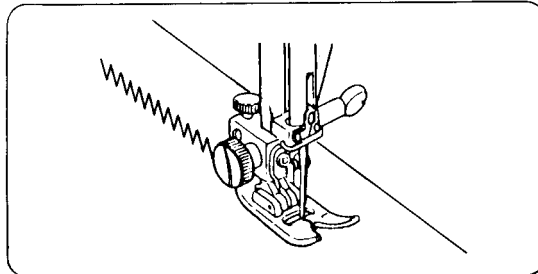



### Machine Setting

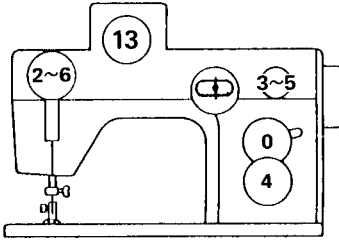
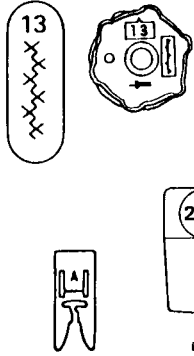

### Triple Strength Stitch

This strong, durable stitch is recommended where both elasticity and strength are needed to insure comfort and durability.

Use it to reinforce areas such as crotch and armhole seams.

Also use when constructing items such as backpacks for extra strength.

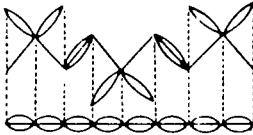

When using the pattern cam No. 13 with the stitch width dial set at "0", the triple strength straight stitch is obtained.

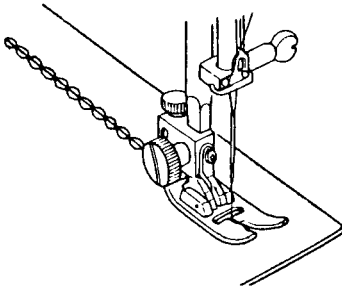

The stitch is sewn with two stitches forward and one stitch backward forming a seam that does not rip easily.

Garments should be basted for fitting before seaming.

## Machine Setting

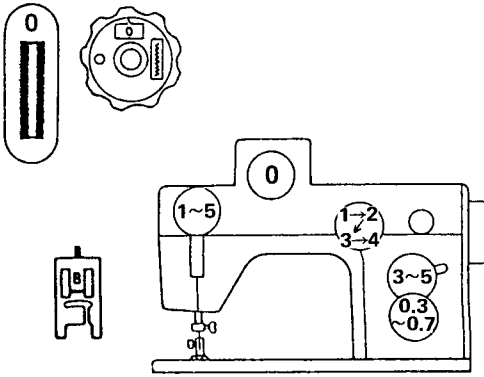

## Buttonholes

The automatic buttonhole device is built in this machine. It sews a buttonhole in a short time without turning the fabric.

Make a test buttonhole and a sample duplicating the fabric, interfacing and seams of the actual garment. Place the button on the fabric sample and mark the top and bottom to determine the buttonhole length.

### ◀ Adjusting Stitch Density ▶

The symbol  on the stitch length dial indicates the range of adjustment for buttonhole.

If you want the coarse stitches of the buttonhole, turn the dial toward "1" direction. If you want the dense stitches of the buttonhole, turn the dial toward "0" direction.

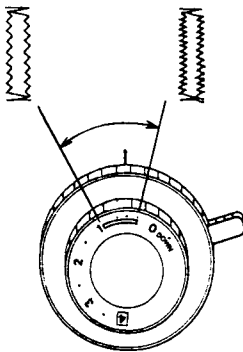

### ◀ Adjusting the Buttonhole Opening ▶

The stitch width dial regulates the opening, the most suitable range will be "3" to "5".

If you want a wider opening, turn the dial toward "5" direction.

If you want a narrower opening, turn the dial toward "3" direction.

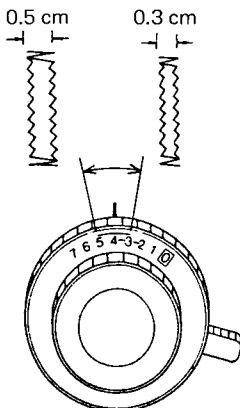

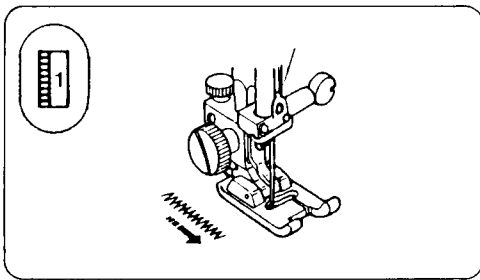

Set the stitch selector dial at “ 1 ”. Slide both threads to the left. Lower the needle into the garment where the buttonhole sewing is to start, and lower the foot. Sew down the left side stopping at the bottom mark. Raise the needle.

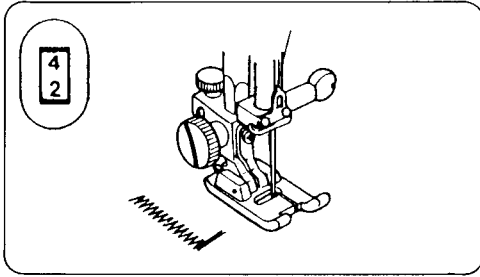

Set the stitch selector dial at “ 2 ”, sew 5 stitches of bartack and raise the needle from the fabric.

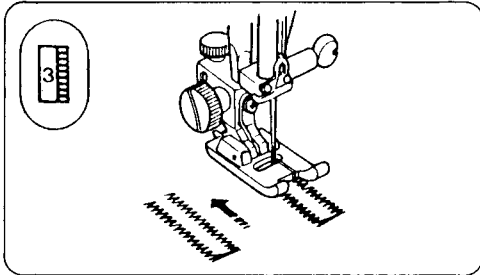

Set the stitch selector dial at “ 3 ”. Sew up the right side of the buttonhole. Stop the machine when you are directly opposite the first stitch on the left hand side and raise the needle.

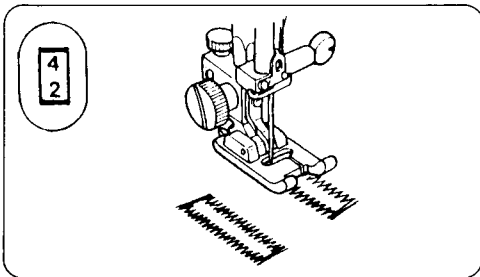

Set the stitch selector dial at “ 2 ”. Sew about 5 stitches of bartack, and remove the fabric from the machine. Cut the both needle and bobbin threads leaving about 10 cm (4”) thread ends. Draw the needle thread to wrong side of fabric by pulling the bobbin thread. Then, knot the threads.

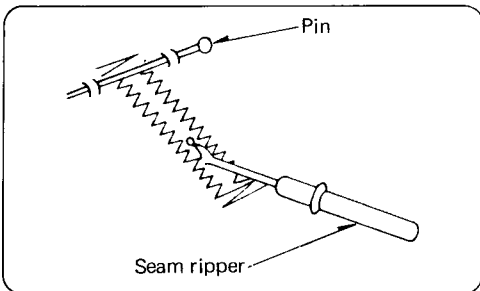

Insert a pin inside the bartack. Then cut the opening with a seam ripper. Take care not to cut the stitches.

## Machine Setting

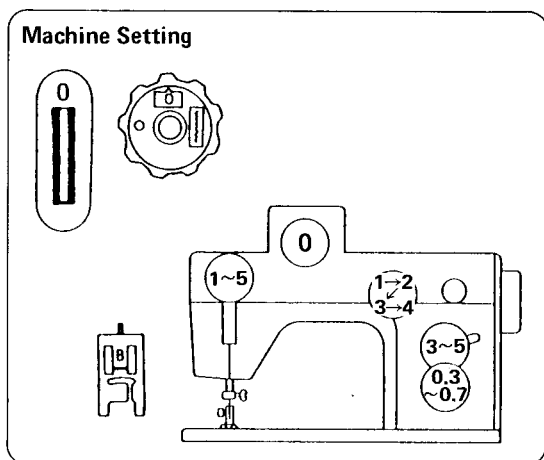

## Corded Buttonhole

Tailored or raised buttonholes can be made by stitching over a filler cord. Embroidery or crochet threads make good filler cords.

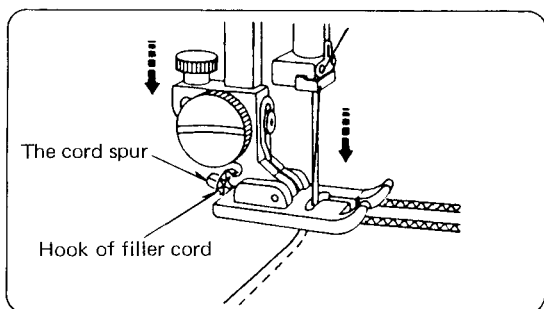

Set the stitch selector dial at “  ”. Hook a filler cord on the cord spur located at the rear of the foot, and bring the ends forward under the foot. Draw both ends of threads to the left. Lower the needle into the garment where the buttonhole sewing is to start, and lower the foot.

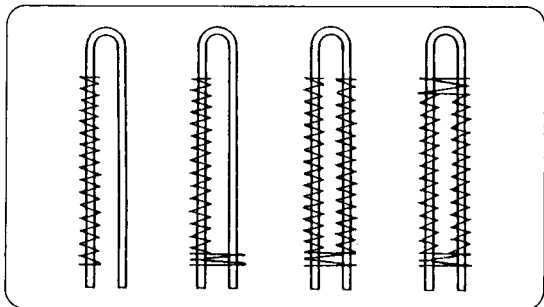

Sew the buttonhole following directions on pages 25 and 26.

Each side of the buttonhole is sewn over the cord.

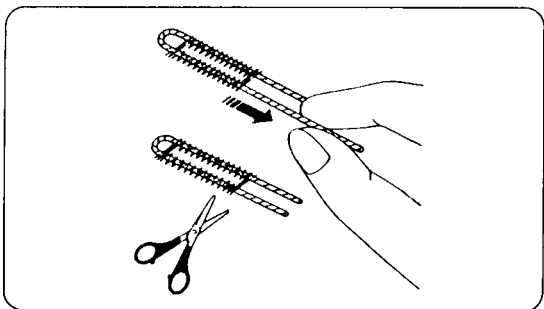

When the buttonhole is completed, remove the fabric from the machine, and cut the sewing threads.

Pull the left end of the filler cords to tighten. Thread the ends through a darning needle, draw to the wrong side of the fabric and cut.

## Zipper Application

### Machine Setting

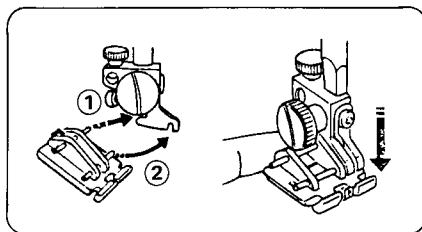
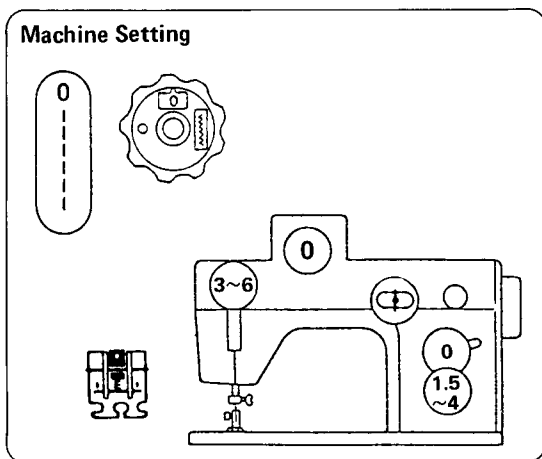

### To attach the zipper foot:

Fit the pin located at the rear of the presser foot into the groove at the rear of the foot holder.

Lower the foot holder to snap the foot on.

- To sew on the left side of the zipper, attach the presser bar to the right pins on the zipper foot.

- To sew on the right side of the zipper, attach the presser bar to the left pins on the zipper foot.

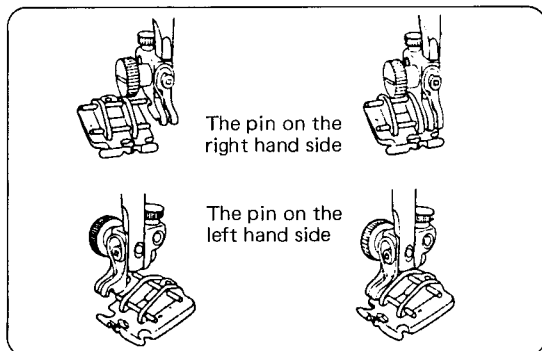

### Fabric Preparation:

Place right sides of fabric together and sew to the end of the zipper opening. Reverse stitch to knot the stitches. Sew the zipper opening with a basting stitches.

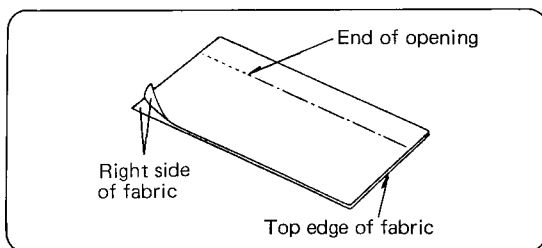

### To sew:

- ① Fold back the left seam allowance. Turn under the right seam allowance to form a 0.2 to 0.3 cm (1/8") fold. Place the zipper teeth next to a 0.2 to 0.3 cm (1/8") fold and pin in place.

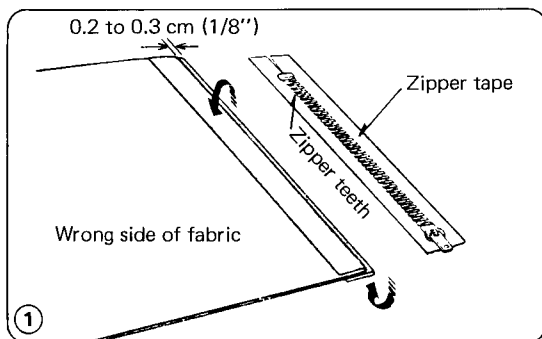

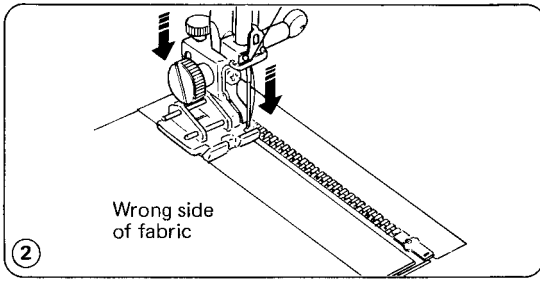

② Attach the zipper foot with the pins on the right hand side. Lower the zipper foot.

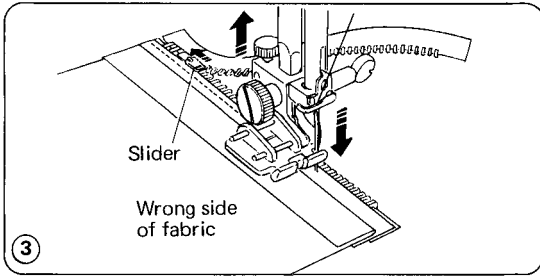

③ Sew through fold and zipper tape. Stop just before the zipper foot reaches the slider on the zipper tape.

Turn the balance wheel by hand and lower the needle into the fabric. Raise the zipper foot and open the zipper. Lower the foot and stitch the remainder of the seam.

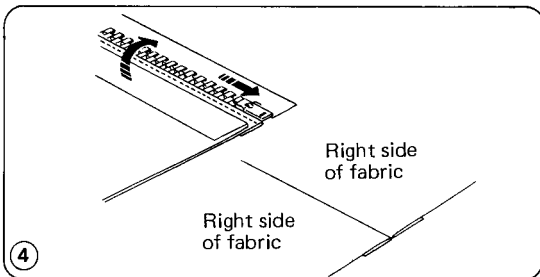

④ Close the zipper and spread the fabric flat with the right side facing up.

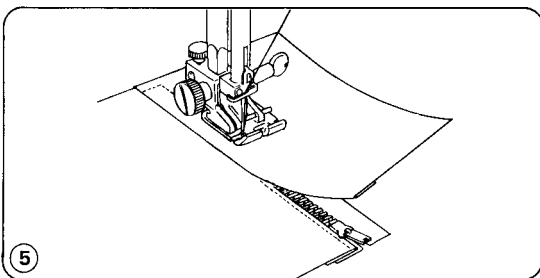

⑤ Move the zipper foot to the left pins. Guide the edge of the foot along the zipper teeth and stitch through garment and zipper tape. Stop about 5 cm (2") from the top of the zipper.

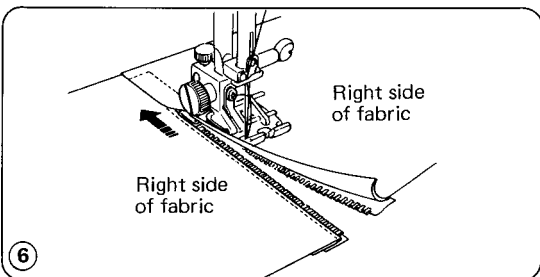

⑥ With the needle down in the fabric, raise the foot, remove the basting stitches and open the zipper. Then lower the foot and stitch the remainder of the seam making sure the fold is even.

## Blind Stitch Hemming

### Machine Setting

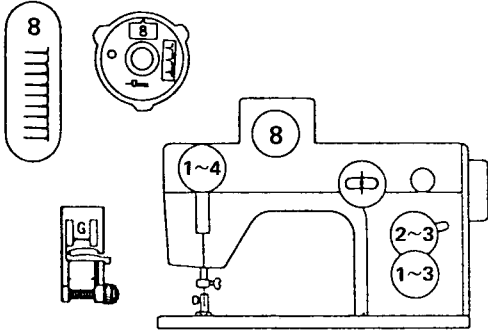

### « How to Fold the Fabric »

On heavy weight fabrics that ravel, the raw edge should be overcast first. On light weight fabrics the raw edge can be turned under and pressed.

Fold up the hem the desired amount and pin in place. Fold the hem under the fabric as illustrated.

0.4 to 0.7 cm  
(5/32 to 9/32")



Light weight fabric



Heavy weight fabric

### « How to Set the Guide »

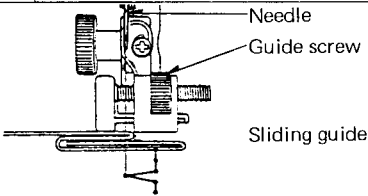

### « How to Sew »

When the needle comes to the left

When the needle comes to the right

- ① Position the fabric on the machine so that the needle just pierces the folded edge of the fabric when the needle comes over to the extreme left side. Lower the presser foot.

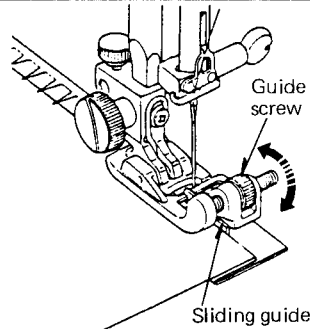

- ② Turn the guide screw and move the sliding guide against the folded edge. Sew the folded edge guiding along the sliding guide.

## Machine Setting

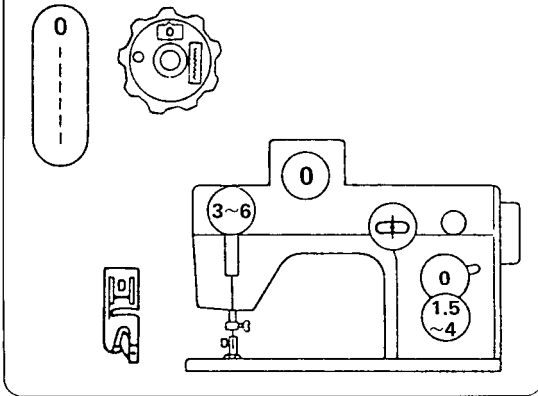

## Rolled Hem

Rolled hems are attractive finish for scarfs, table linens and as edge finishes on tricot lingerie fabrics.

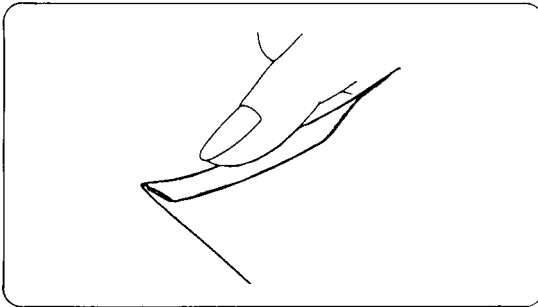

Make a double 0.25 cm (1/8") fold approximately 8 cm (3") in length.

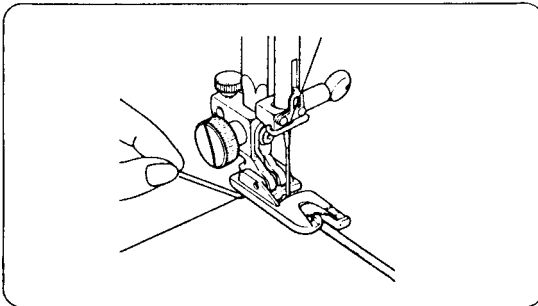

Lower the needle into the fabric at the point where sewing is to begin, then lower the hemmer foot.

Sew 3 or 4 stitches while holding the needle and bobbin threads.

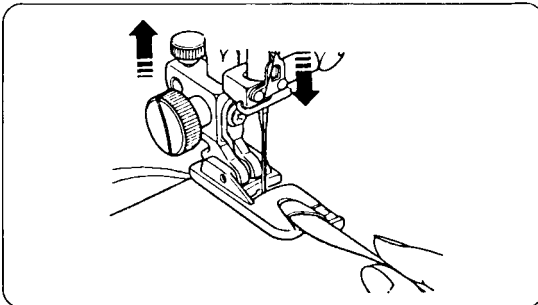

Lower the needle into the fabric and lift the hemmer foot. Insert the folded portion of the fabric into the curl of the hemmer foot.



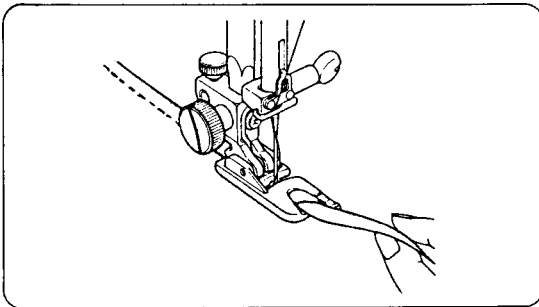

Lower the hemmer foot, then sew by lifting up the edge of the fabric to keep it feeding smoothly and evenly.

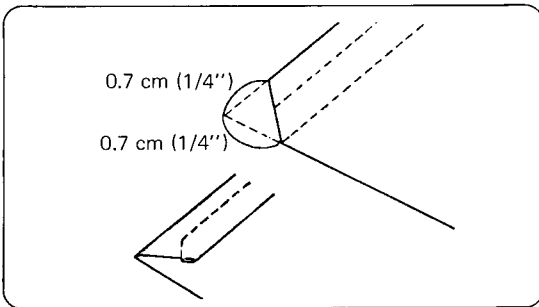

Trim about 0.7 cm (1/4'') from corners as illustrated, to reduce bulk.

# SECTION IV PERSONAL TOUCH OR DECORATIVE SEWING

## Machine Setting (1)

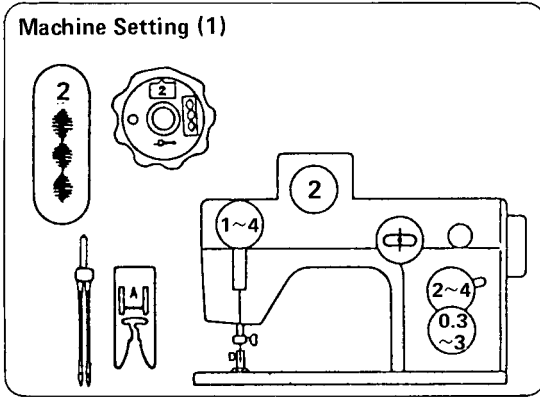

## Twin Needle Stitching







Twin needle is used to sew parallel rows of straight and decorative stitches adding an exquisite touch to table linens and clothing.

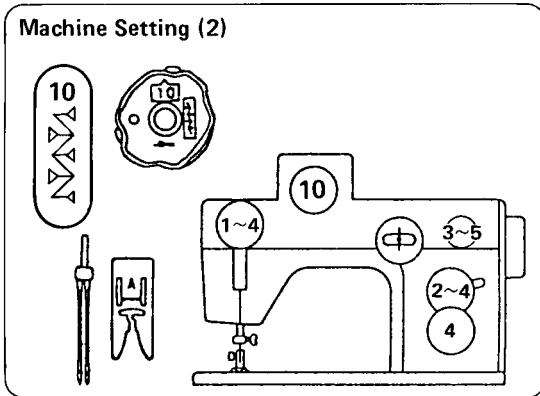

Always set the stitch selector dial at , when twin needle sewing.

\* Attach the twin needle after setting the dials.

## Machine Setting (2)



When you sew pattern numbers , , , , and  through , set the machine as shown on the above left.

When you sew pattern numbers  through  set the machine as shown on the left.

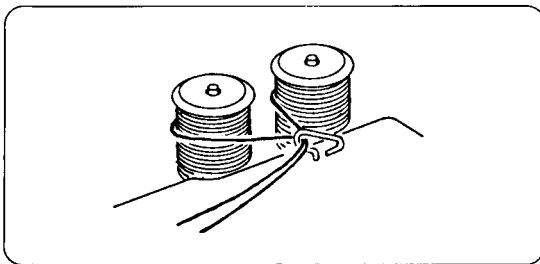

## « Threading »

Place the spools of thread on the spool pins, and thread the machine as for single thread stitching.

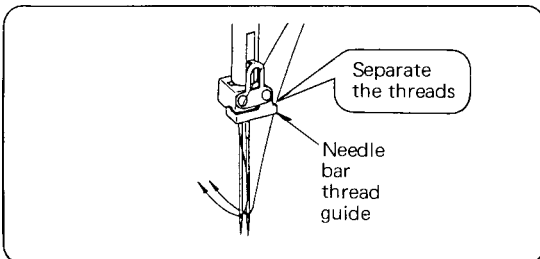

Slip one of the threads into the needle bar thread guide on the left, and the other one on the right. Then thread the both needles respectively.

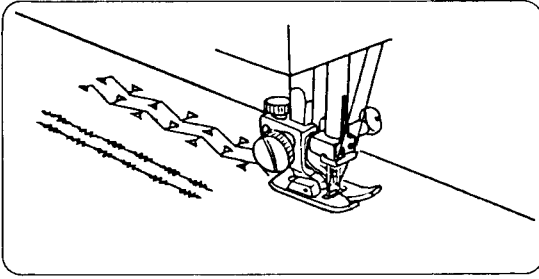

Sew parallel rows. When reached at the corner, raise the needle till they clear the fabric, and then raise the presser foot and carefully pivot the fabric.

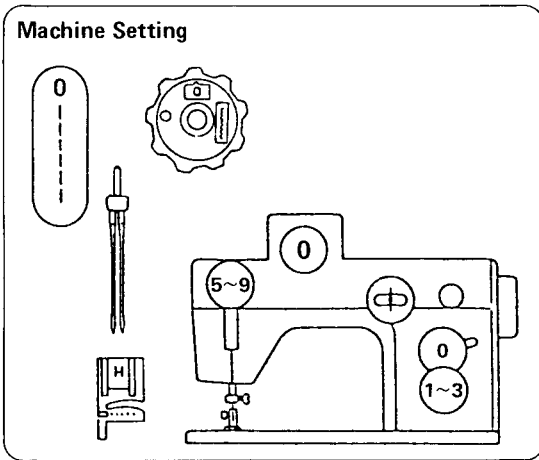

## Pintucking

Pintucks are narrow tucks spaced close together adding design interest on such items as blouses and pillowcases.

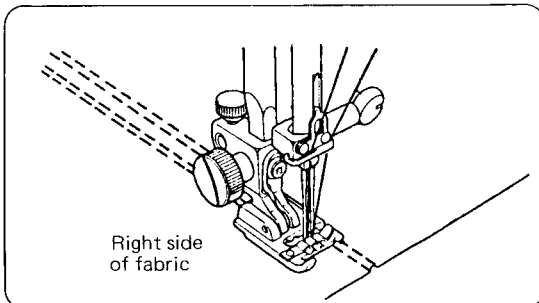

Sew on the right side of the fabric through a single layer. Hold the fabric taut while sewing.

When sewing several rows of pintucking, place the previous row under the groove farthest to the right on the bottom of foot. The groove will keep the rows parallel.

### Machine Setting (1)

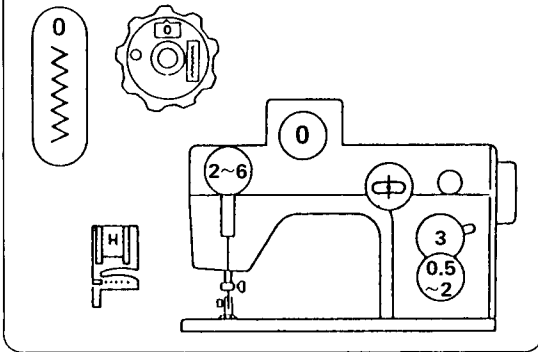

## Cording

Sew over one strand of cording to create a pretty swirled design on a jacket or vest or sew over three strands of cording for border trims. Perle cotton, knitting yarn or embroidery floss can be used for cording.

### ◀ Single Cording ▶

Mark the design on the right side of the fabric. Insert cording in the center groove of the foot with 5 cm (2") extending behind the foot.

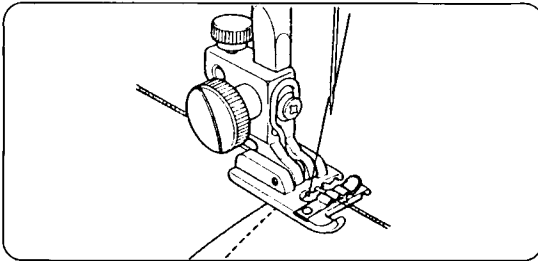

Stitch slowly and smoothly turning the fabric as you sew while guiding the cording over the marked line.

### Machine Setting (2)

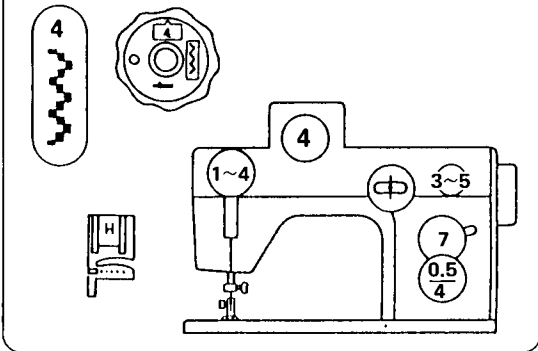

### ◀ Triple Cording ▶

Use pattern  or .

When you use the pattern , set the stitch length dial at "4".

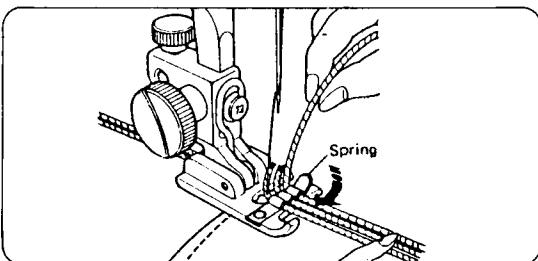

Draw the ends of sewing threads to the left and under the foot and insert three strands of cording into the slots of foot with 5 cm (2") extending behind the foot.

The slots on foot will hold the lengths of cording in place while the stitches form over the cording.

### Machine Setting

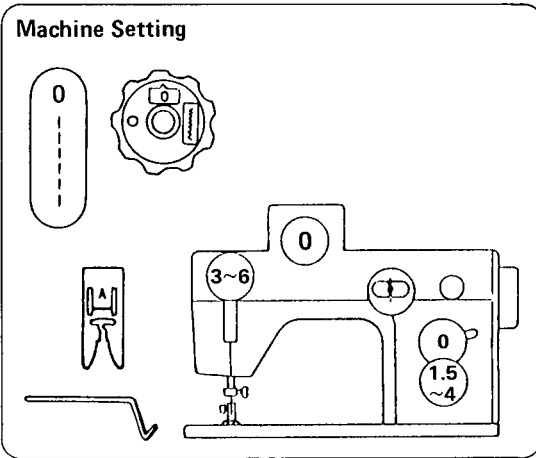

### Quilting

Quilting is produced by stitching two layers of fabric together with batting in between to add dimension and warmth. Traditionally used for bedspreads, quilting is now applied everywhere.

Test the sewing and check the tension and stitch length on a fabric sample duplicating the layers of the actual quilting.

Puckering can be reduced by quilting on the bias.

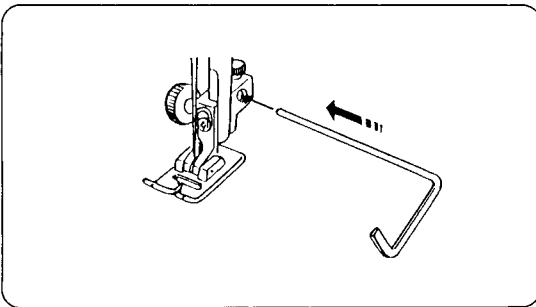

The quilting guide will help to keep the stitching lines straight and parallel. Loosen the quilter screw. Slide the quilter in the hole to the desired width and tighten the screw.

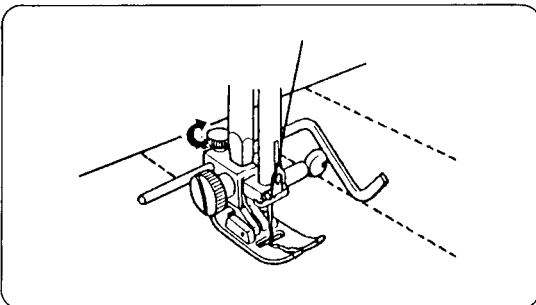

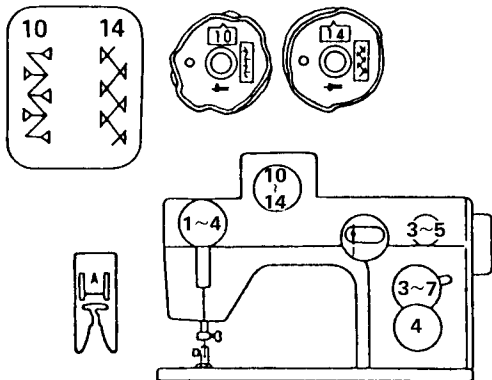

Sew guiding the quilter over the previous row of stitching.

### Machine Setting



### Smocking

A delicate, decorative treatment, smocking can be applied whenever gathers are used. Turn a child's dress into something very special or smock a yoke on a peasant blouse. Choose a soft, lightweight fabric such as batiste, gingham or challis. Cut the fabric three times as wide as the finished width.

Use one of the patterns  through  or  .

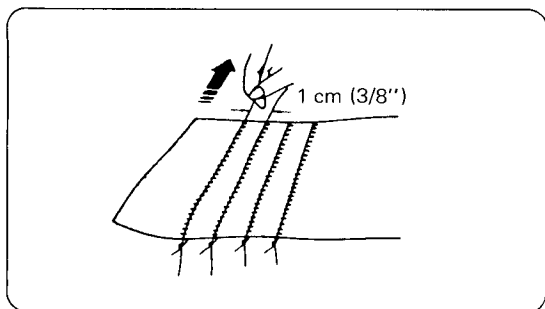

With setting the stitch length dial at "4" and sew straight lines 1 cm (3/8") apart, across the area to be smocked. A looser needle thread tension will make gathering easier. Knot the threads along one edge. Pull the bobbin threads and distribute the gathers evenly. Secure the threads at the other end.

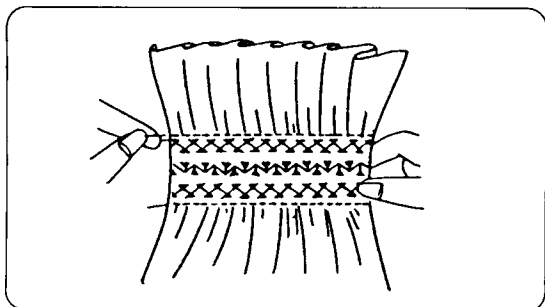

Reduce the tension and pressure if necessary and sew pattern stitches between the straight seams.

Pull out the gathering stitches.

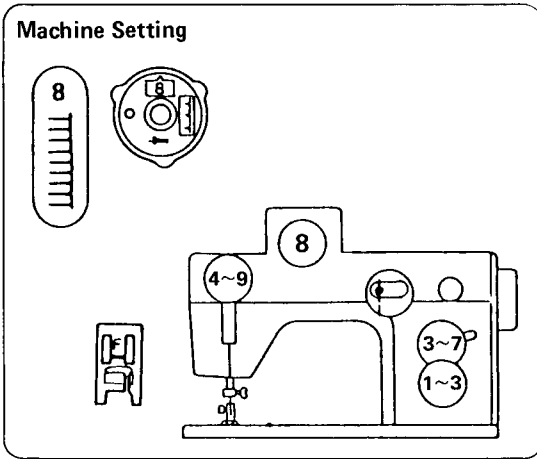

## Shell Tuck

Shell tucking adds a sophisticated, elegant finish on blouses and lingerie. The tucks are formed by sewing a blind hem stitch over folded rows of fabric. It can be used to finished hems, sleeve and neck openings or create scalloped tucks on blouses and lingerie.

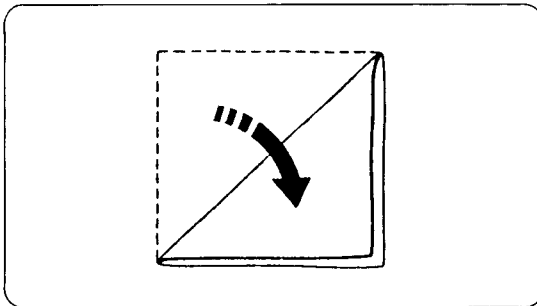

Knits can be tucked in any direction. Wovens should be folded and stitched on the bias for best results. Place folds about 1.5 cm (1/2") apart for rows of tucks.

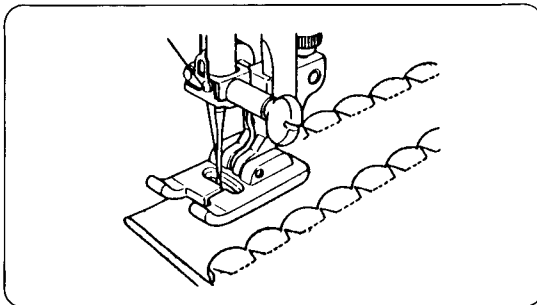

Place the folded edge to the left. The needle should fall of the edge of the fabric on the left forming a tuck.

## Machine Setting

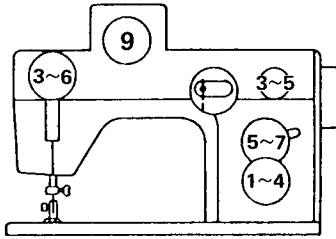
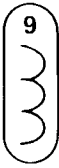

## Scallop Hems

This machine provides a special pattern for scalloping hems on curtains, children's clothes, lingerie and linens.

Stitch Length	Seam Variations
4	
2	
1	

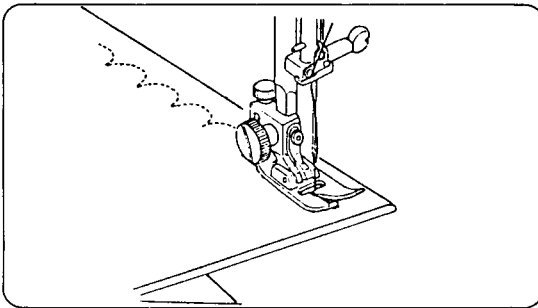

Fold hem with right sides together. Sew scallops 1 cm (3/8") from folded edge.

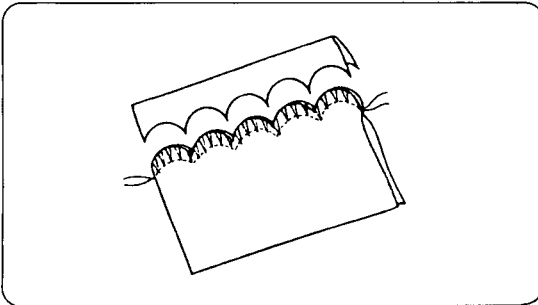

Trim close to stitching leaving 0.3 cm (1/8") seam allowance. Clip seams as shown or trim with pinking shears.

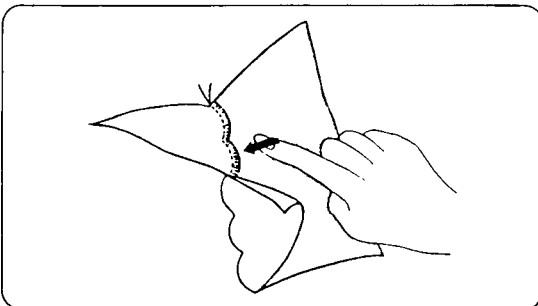

Turn them to right side and push.



### Machine Setting (1)

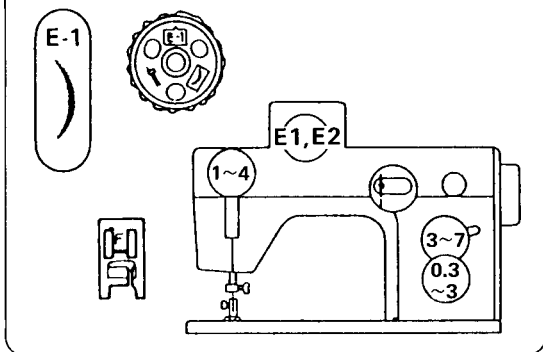



### Decorative Scallop

This scallop can be used to finish attractively the edges of collars, pockets and placemats.

Use pattern  or  .

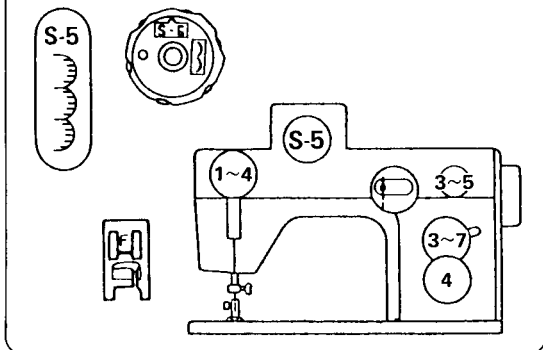
### Machine Setting (2)



When you sew pattern number  , set the machine as shown on the left.

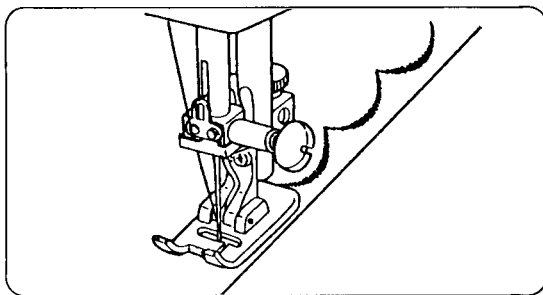

Fold the garment wrong sides together and press. Sew 1 cm (3/8") from the folded edge.

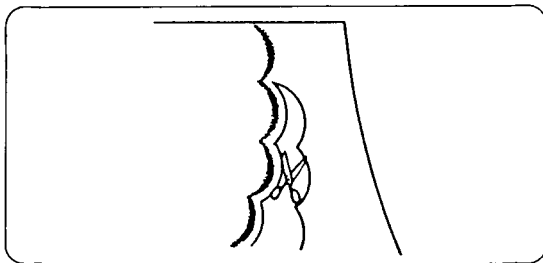



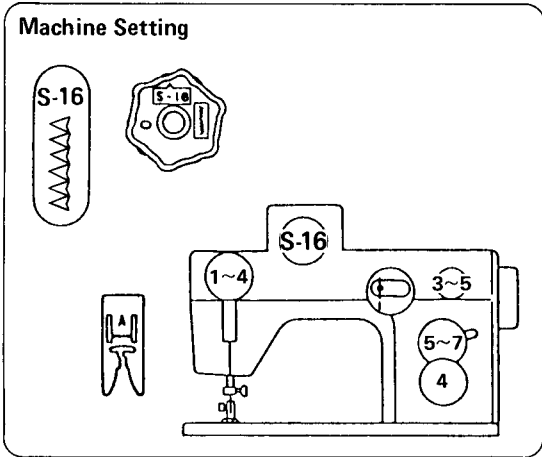

Trim close to the stitching while being cautious not to cut the thread.



**Lace Work**

Lace adds a fanciful, feminine touch to blouses and lingerie. Table linens and pillows become more elegant when trimmed with lace.

Use one of the patterns  through   
 or  through .

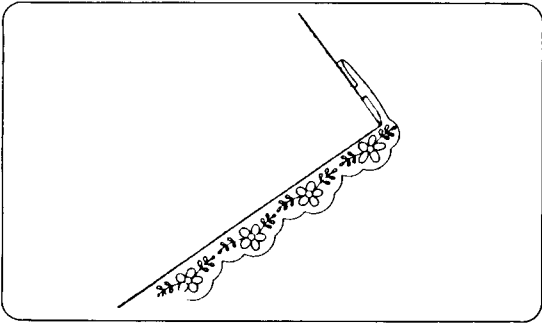

Fold the raw edge under the hem and place the lace under the folded edge.

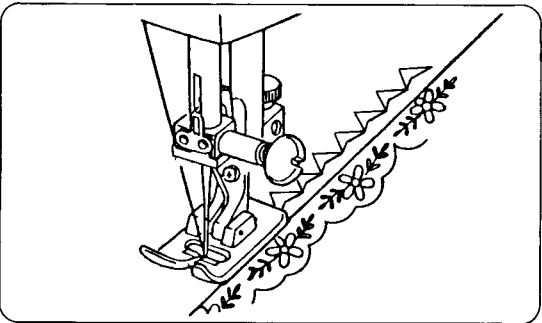

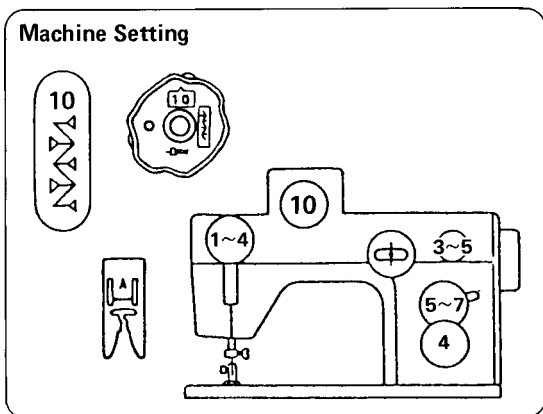

Then sew the pattern stitch making sure the lace is caught in the stitching.

### Machine Setting



### Patch Work

You can join fabrics with both reinforcing and decorating seams.  
You may also use quilting for patch work.

Use one of the patterns  through 

or  .

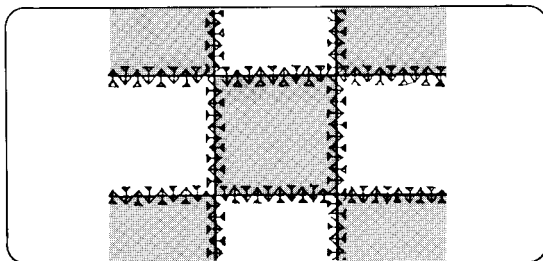

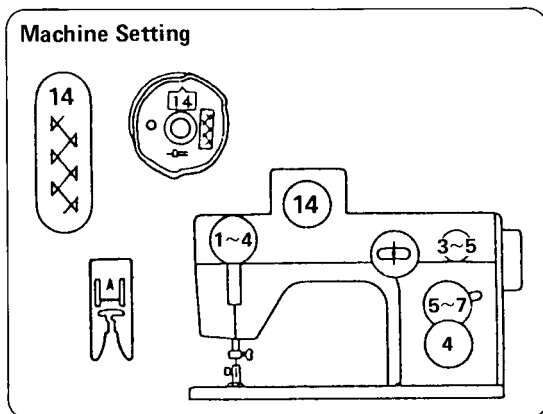

Sew the pattern on a seam that is already jointed and pressed flat.

### Machine Setting



### Fagoting

An open worked stitch used to join two pieces of fabric adding design interest to plain garments. Topstitching threads in the needle and bobbin give a hand worked appearance.

Use one of the patterns  through 

or  .

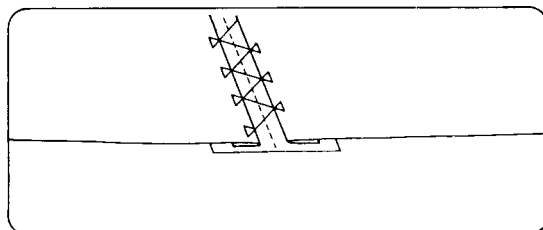

Fold under 1.5 cm (1/2") on each fabric edge and press. Pin the two edges to paper 0.3 cm (1/8") apart.

Sew slowly guiding the fabric so the needle catches the folded edge on each side.

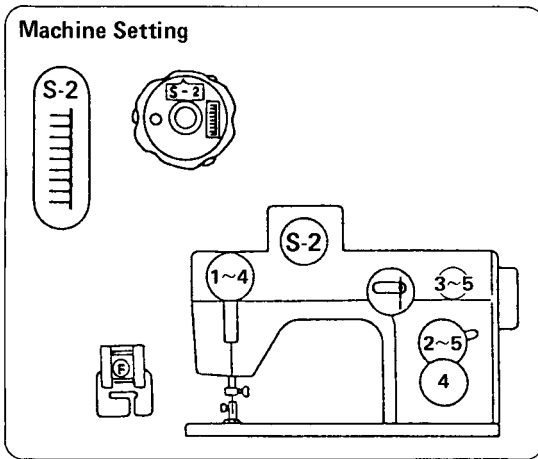

## Applique

Applique, a technique for stitching fabric shapes onto another fabric opens limitless design possibilities. Dimension and texture can be added by lightly stuffing all or part of a design.

In this type of applique raw edges are folded under. To finish raw edges cut the applique design out of cardboard.

Fuse a light weight interfacing to the wrong side of the fabric then cut the fabric slightly larger than the cardboard. Fold the fabric around the cardboard and press to form a perfectly shaped design.

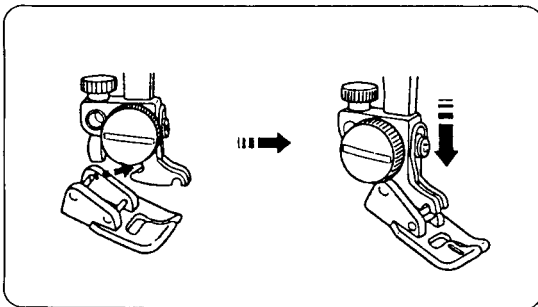

### To attach the applique foot:

- ① Fit the pin located at the rear of the presser foot into the groove at the rear of the foot holder.
- ② Lower the presser foot lifter to snap the foot on.

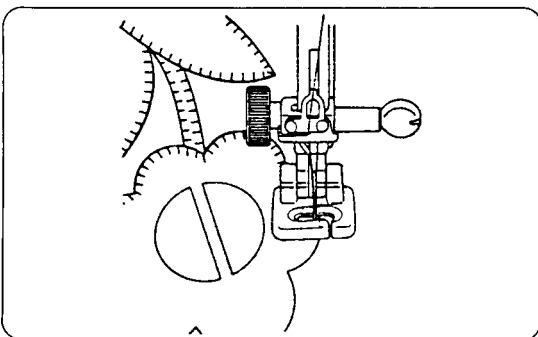

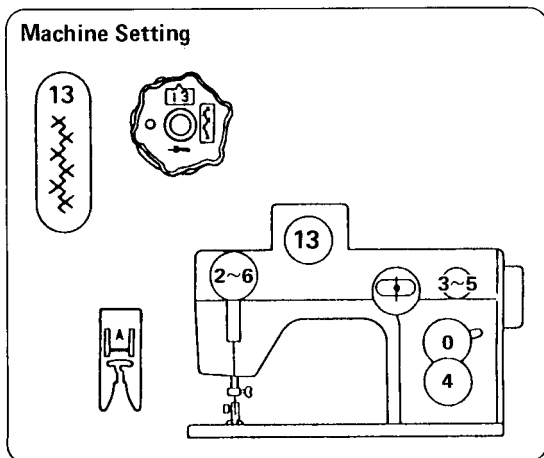

Tape the applique in place and sew guiding the slot on foot next to the finished edge of the applique.



## Drawn Work and Fringing

Drawn work and fringing add a special touch the table linens and showls.

Choose a firm, plain weave fabric such as linen where threads can be removed easily.

Use pattern  or .

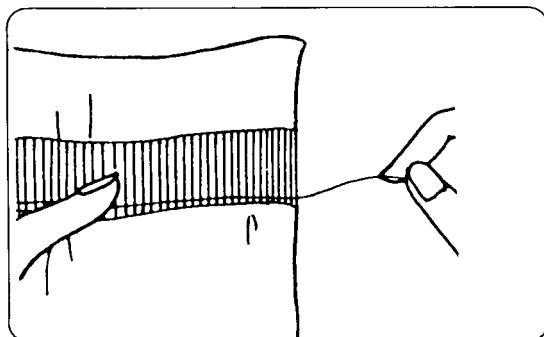

Carefully cut the fabric on grain.

Determine the width of the drawn work and remove one yarn at each end.

Sew down the left side guiding the fabric so the needle falls in the open space.

Then sew down the right side.

Remove the yarns between the stitching.

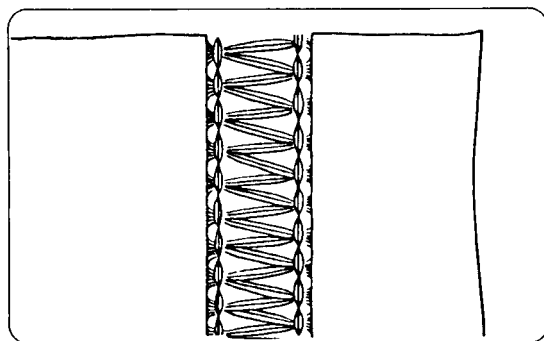

Fringing is sewn in the same way.

Remove a single yarn where fringing is to begin and stitch. Remove the remaining yarns.

## Machine Setting

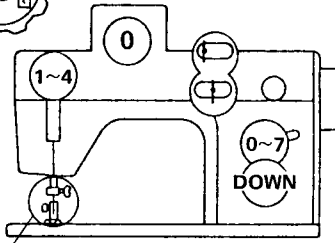

Remove the foot holder

## Free Hand Machine Embroidery

In this type of embroidery, fabric is placed in an embroidery hoop and the design is formed by guiding the fabric as you sew.

Use a 15 cm (8") embroidery hoop with an adjustable screw, size 11 (75) blue tipped needle, standard or machine embroidery thread in the needle and soft basting thread or white embroidery thread in the bobbin.

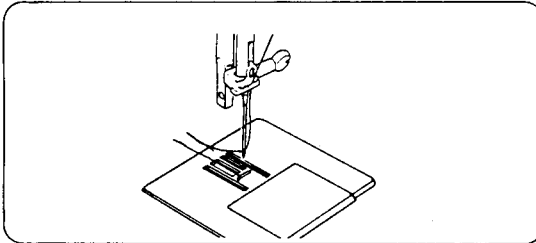

Remove the foot holder from the machine.

When putting the embroidery hoop under the needle, raise the needle to its highest position and lift the presser foot lifter for giving an extra high lift.

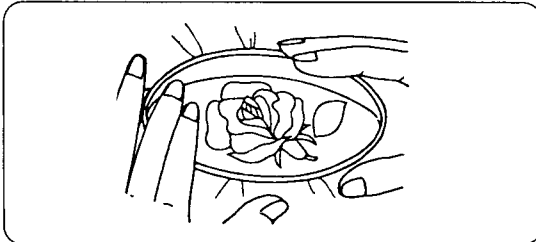

Draw your desired design on the fabric with a pencil or tailor's chalk.

Stretch and set the fabric in an embroidery hoop.

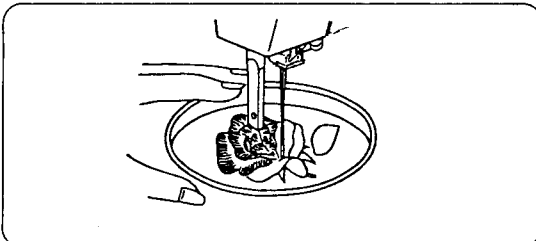

The presser foot lifter should be lowered to engage the thread tension when sewing.

While moving the hoop slowly with your left hand, follow the design on the fabric.

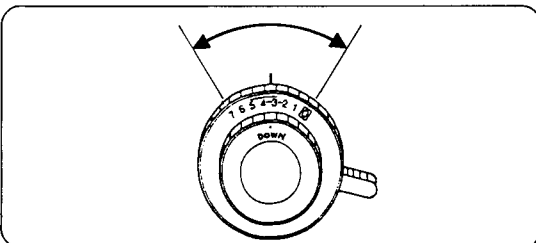

Move the stitch width dial with your right hand to change the zigzag width.

## SECTION V CARING FOR YOUR MACHINE

### Oiling the Machine

Unscrew and remove the face plate.  
Apply a few drops of fine quality sewing machine oil to the points indicated by the arrows in the figures.

For a machine in constant use, oil two or three times a year.

In case the machine does not work smoothly due to standing idle for some time, apply a few drops of kerosene at the oiling points, and run the machine rapidly for a minute.

Before oiling, wipe off the oiling points.

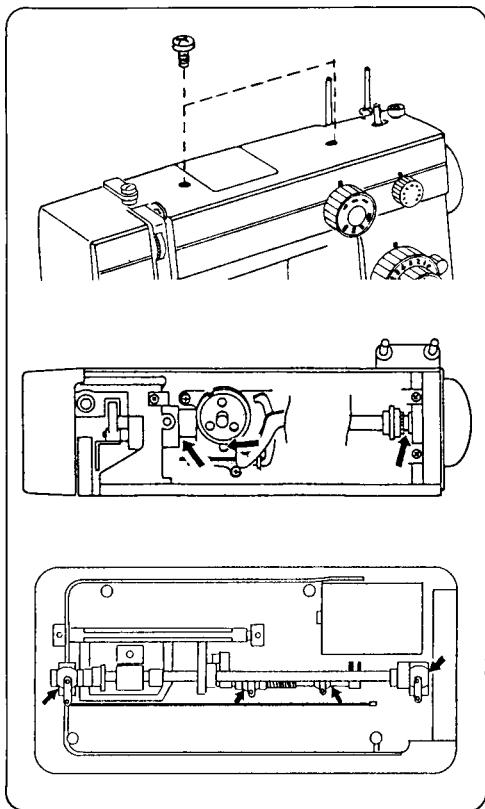
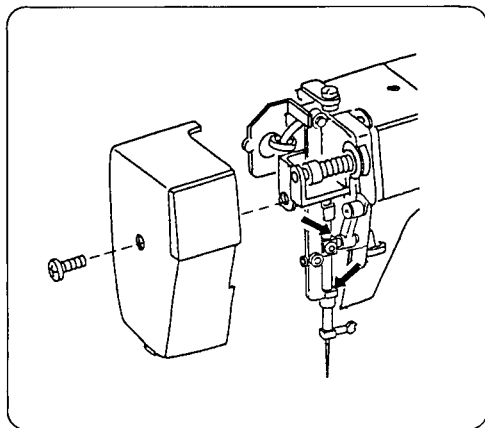

Remove the two screws and take off the top cover. Apply a few drops of fine quality sewing machine oil to the points indicated by the arrows in the figures.

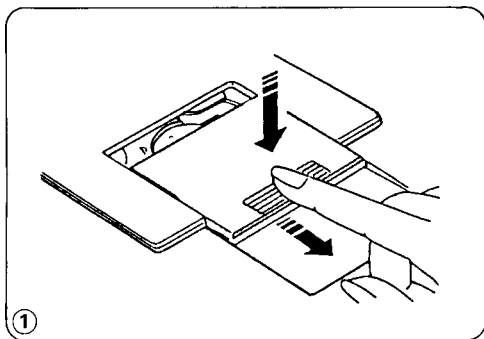

\* Before cleaning, unplug your machine and raise the needle.

### Cleaning the Bobbin Holder

- ① While pushing the front end of slide plate, slide it toward you as far as it will go.

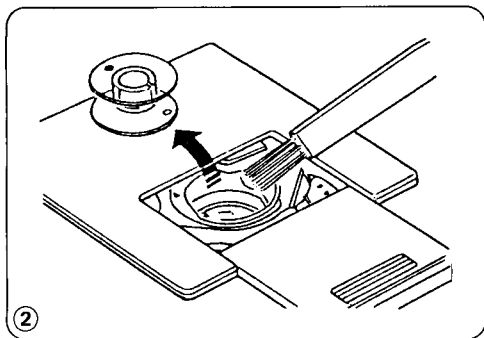

- ② Take out the bobbin, and remove lint with lint brush. You may use vacuum cleaner.

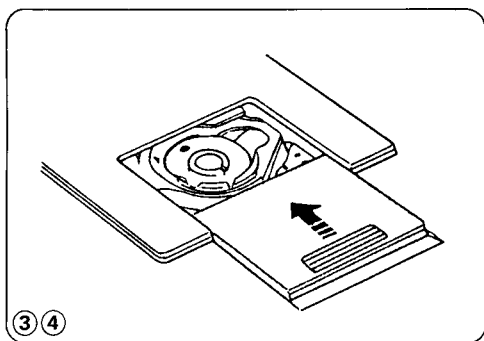

- ③ Insert the bobbin.
- ④ Close the slide plate.



## Cleaning the Hook Race and Feed Dog

- ① Remove the needle and presser foot. Remove the needle plate by unscrewing its set screws with a screw driver.

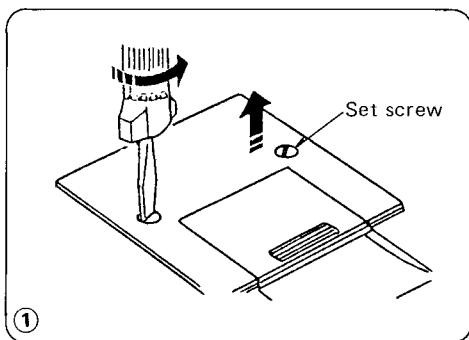

- ② Take out the bobbin.

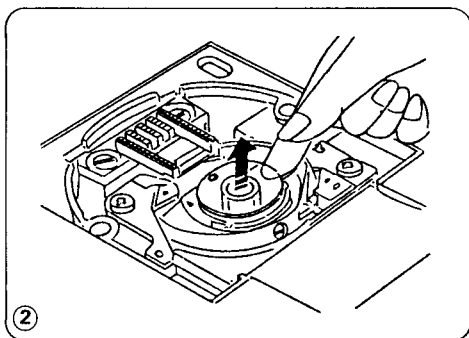

- ③ Lift up the front end of bobbin holder to remove it.

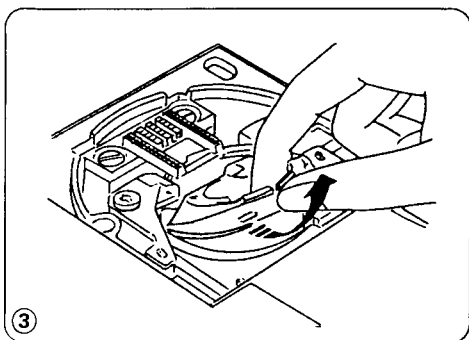

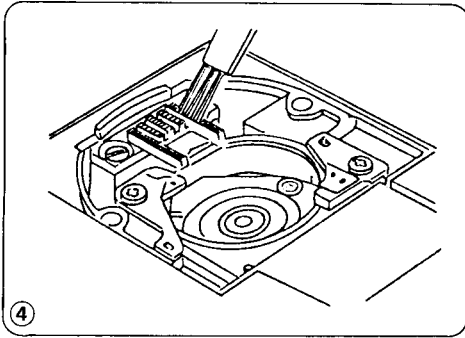

- ④ Brush off the lint on the feed dog.

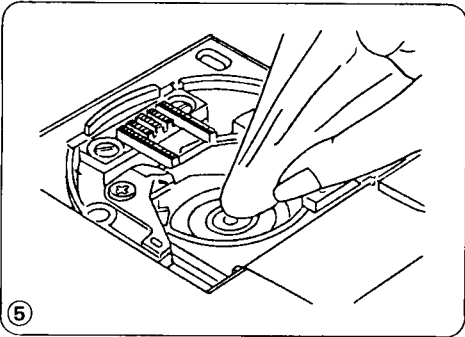

- ⑤ Wipe the hook race with a soft dry cloth.

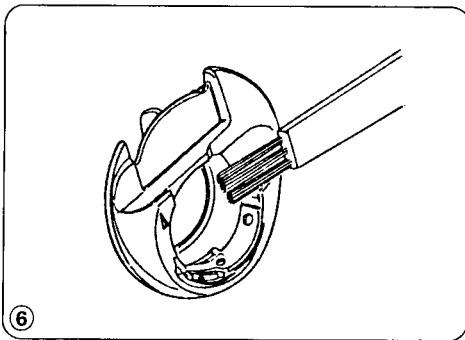

- ⑥ Clean the bobbin holder with a lint brush and a soft dry cloth.

## Resetting the Bobbin Holder and Needle Plate

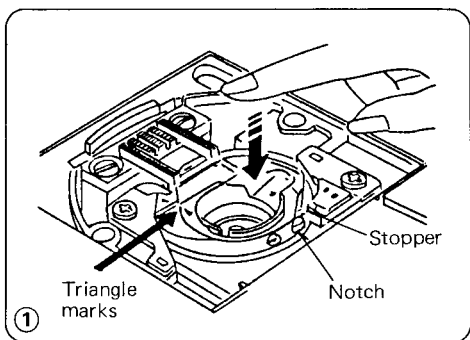

- ① Line up the triangle marks and position the bobbin holder so that the notch fits next to the stopper in the hook race.

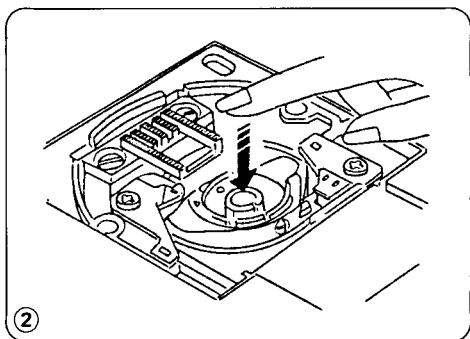

- ② Put the bobbin in.

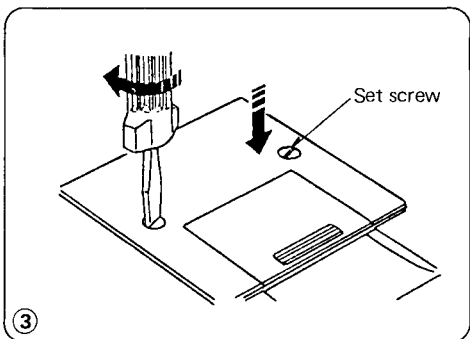

- ③ Attach the needle plate with two set screws. Insert the needle, and attach the presser foot.

## Trouble Shooting

Condition	Cause	Reference
<b>The machine does not run smoothly and is noisy.</b>	<ol style="list-style-type: none"> <li>1. Threads have been caught in hook mechanism.</li> <li>2. The feed dog is packed with lint.</li> </ol>	See Pages 47~50
<b>The needle thread breaks.</b>	<ol style="list-style-type: none"> <li>1. The needle thread is not threaded properly.</li> <li>2. The needle thread tension is too tight.</li> <li>3. The needle is bent or blunt.</li> <li>4. The needle is incorrectly inserted.</li> <li>5. The fabric is not being drawn to the back when sewing is finished.</li> <li>6. The thread is either too heavy or too fine for the needle.</li> </ol>	See Page 9 See Page 12 See Page 11 See Page 11 See Page 17  See Page 11
<b>The bobbin thread breaks.</b>	<ol style="list-style-type: none"> <li>1. The bobbin thread is not threaded properly in the bobbin holder.</li> <li>2. Lint has been collected in the bobbin holder and/or tension spring.</li> <li>3. The bobbin does not rotate smoothly.</li> </ol>	See Page 8  See Pages 47~50  Replace the bobbin.
<b>The needle breaks.</b>	<ol style="list-style-type: none"> <li>1. The needle is incorrectly inserted.</li> <li>2. The needle is bent or blunt.</li> <li>3. The needle clamp screw is loose.</li> <li>4. The tension of the needle thread is too tight.</li> <li>5. The fabric is not drawn to the back when sewing is finished.</li> <li>6. The needle is too fine for the fabric being sewn.</li> <li>7. The stitch selector dial had been turned while the needle was in the material.</li> </ol>	See Page 11 See Page 11 See Page 11 See Page 12 See Page 17  See Page 11 See Page 14
<b>Skipped stitches</b>	<ol style="list-style-type: none"> <li>1. The needle is incorrectly inserted.</li> <li>2. The needle is bent or blunt.</li> <li>3. The needle and/or threads are not suitable for the work being sewn.</li> <li>4. A BLUE TIPPED needle is not being used for sewing stretch, very fine fabrics and synthetics.</li> <li>5. The needle thread is not threaded properly.</li> </ol>	See Page 11 See Page 11 See Page 11  See Page 11  See Page 9

Condition	Cause	Reference
<b>Seam Puckering</b>	<ol style="list-style-type: none"> <li>1. The needle thread tension is too tight.</li> <li>2. The needle thread and/or bobbin thread are not threaded properly.</li> <li>3. The needle is too heavy for the cloth being sewn.</li> <li>4. The stitches are too coarse for the fabric being sewn.</li> </ol> <p>* When sewing extremely light weight materials, place a sheet of paper underneath the fabric.</p>	<p>See Page 12 See Pages 8~9</p> <p>See Page 11 See Page 14</p>
<b>Stitches form loops below the work.</b>	<ol style="list-style-type: none"> <li>1. The needle thread tension is too loose.</li> <li>2. The needle is either too heavy or too fine for the thread.</li> </ol>	<p>See Page 12 See Page 11</p>
<b>The cloth is not feeding smoothly.</b>	<ol style="list-style-type: none"> <li>1. The feed dog is packed with lint.</li> <li>2. The stitches are too fine.</li> <li>3. The feed dog is not raised after "Drop feed" has been used.</li> </ol>	<p>See Pages 47~50</p> <p>See Page 14</p> <p>See Page 4</p>
<b>The machine does not work.</b>	<ol style="list-style-type: none"> <li>1. The machine is not plugged in.</li> <li>2. A thread is caught in the hook race.</li> <li>3. Bobbin winder clutch knob is not pushed in.</li> </ol>	<p>See Page 3 See Pages 47~50 See Page 7</p>
<b>The buttonhole stitches are not balanced.</b>	<ol style="list-style-type: none"> <li>1. The stitch length is not suitable for the fabric being sewn.</li> <li>2. The work is being pulled or held back.</li> </ol>	<p>See Page 25</p> <p>Do not force the fabric for guiding.</p>
<b>The machine is noisy.</b>	<ol style="list-style-type: none"> <li>1. The machine is in need of oil.</li> <li>2. Dust and lint have collected in the hook mechanism.</li> <li>3. The feed dog is packed with lint.</li> </ol>	<p>See Page 46 See Pages 47~50</p> <p>See Pages 47~50</p>

803-800-001 (E-N)